

CLEANJET SPRAYER / FOAMER



TECHNICAL CHARACTERISTICS:

Water supply connection	Connection on left side with elbow		
Inlet connection type	Female ¾" GHT		
Outlet connection type	Male ¾" GHT		
Chemical product channel flow rate	Water supply of 8gal/min flow rate and 50psi: 2.5 gal/min		
Rinse channel flow rate	Water supply of 8gal/min at 50psi: 3.4 gal/min		
Maximum dimensions	H = 400mm (15.75")	L = 330mm (13")	D = 160mm (6.3")
Working pressure	Min 22 PSI (1.5 bar)		Max 85 PSI (6 bar)
	Optimum: 30 – 60 PSI (2 – 4 bar)		
Temperature	Max 140°F (60°C)		



PLEASE READ THE FOLLOWING WARNINGS BEFORE INSTALLING OR SERVICING THE CLEANING STATION

- Make sure that the water supply pressure is between 22 -85 PSI, in case of excessive pressure use a pressure regulator to avoid breackage.
- Make sure that the water supply temperature does not exceed 140° (60°C)
- The ProTwin's fittings have been tested with commonly used liquid detergents mixed with water.
- Check that the detergent used is compatible with polypropylene.
- Install the station near as possible to a water supply connection point.
- Mount the CleanJet considering easy access for cleaning and routine maintenance.



WARNING: Disconnect water supply before servicing the CleanJet.



WARNING: THE MAXIMUM OPERATING PRESSURE is 6 bar (85 PSI) and is intended as a maximum static pressure applicable to the system. Care should be taken that the equipment cannot produce scenarios of over pressurization, which could cause damage to the structure of the system. The use of a pressure reducer is always recommended and the installation of a tap on the water outlet of the system which can be closed when the system itself is not in use.



WARNING: Follow common safety procedures. Use adequate protection for the eyes, face, hands, and clothing.



We constantly work to improve our products and reserve the right to make changes at any time without prior notice.



Failure to follow these safety precautions may cause personal injury or damage to the equipment.



Only use recommended accessories.

INSTALLATION

The CleanJet should be installed where it is easily connected to the water supply. Before mounting, check that all valves can be easily operated and exposed surfaces are accessible for cleaning and routine maintenance.

Positioning and drilling plans:

Remove the CleanJet from the box and remove the cover by removing the screws at the top and pressing the release tabs. You can now access to the mounting holes (located on the rear panel). Mount the CleanJet on the wall using the supplied anchors, screws and washers. The versatility of the CleanJet allows the hose bracket to be installed as an integrated part of the unit or mounted independently as pictured below.

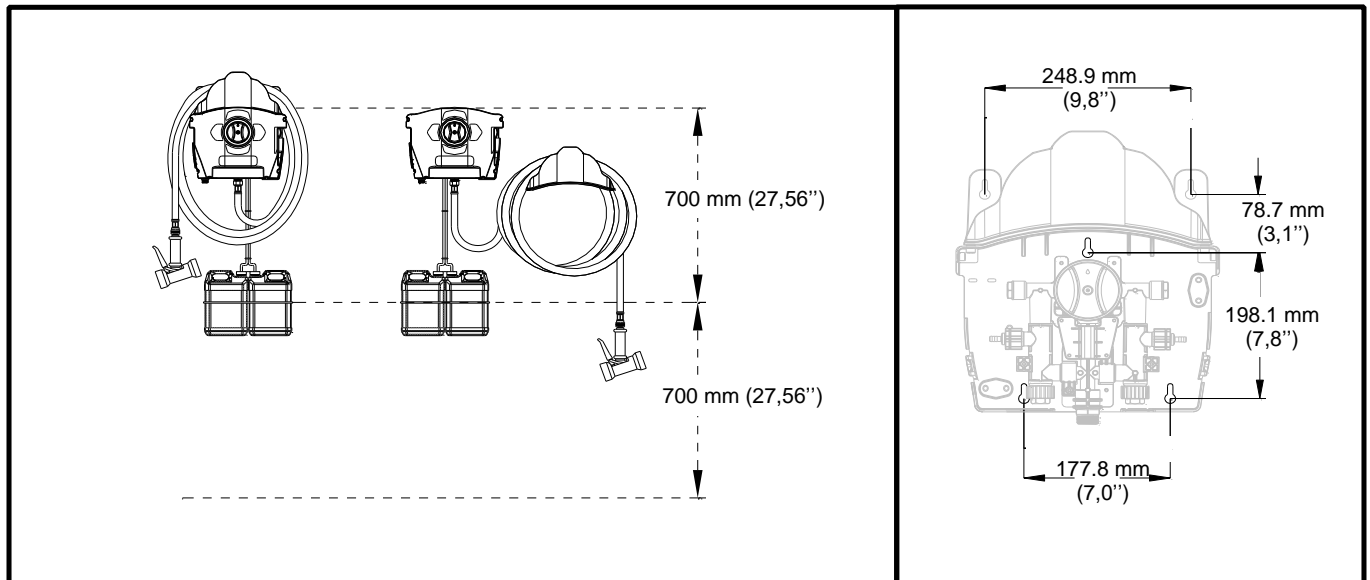
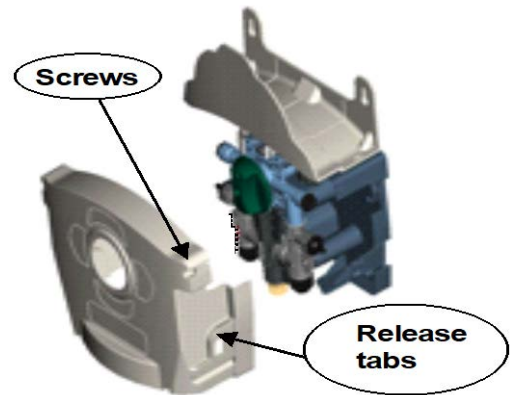

Figure 2 – Drilling plans and positioning

PACKAGE CONTENTS:

1. CleanJet te
2. Suction hose 1.83m / 6ft (1 roll for each product)
3. Hose bracket
4. Complete installation kit:
 - Water inlet elbow fitting 3/4" GHT
 - Plastic hose clamps (2 for each product)
 - 15 metering tips (1 bag for each product)
 - 4 ultra-lean tips (1 bag for each product)
 - Foot valve (1 for each product)
 - Ceramic weight (1 for each product)
 - Suction elbow (1 for each product)
 - Wall anchors (3 pcs)
 - Screws (3 pcs)
 - Washers (3 pcs)

How to install:

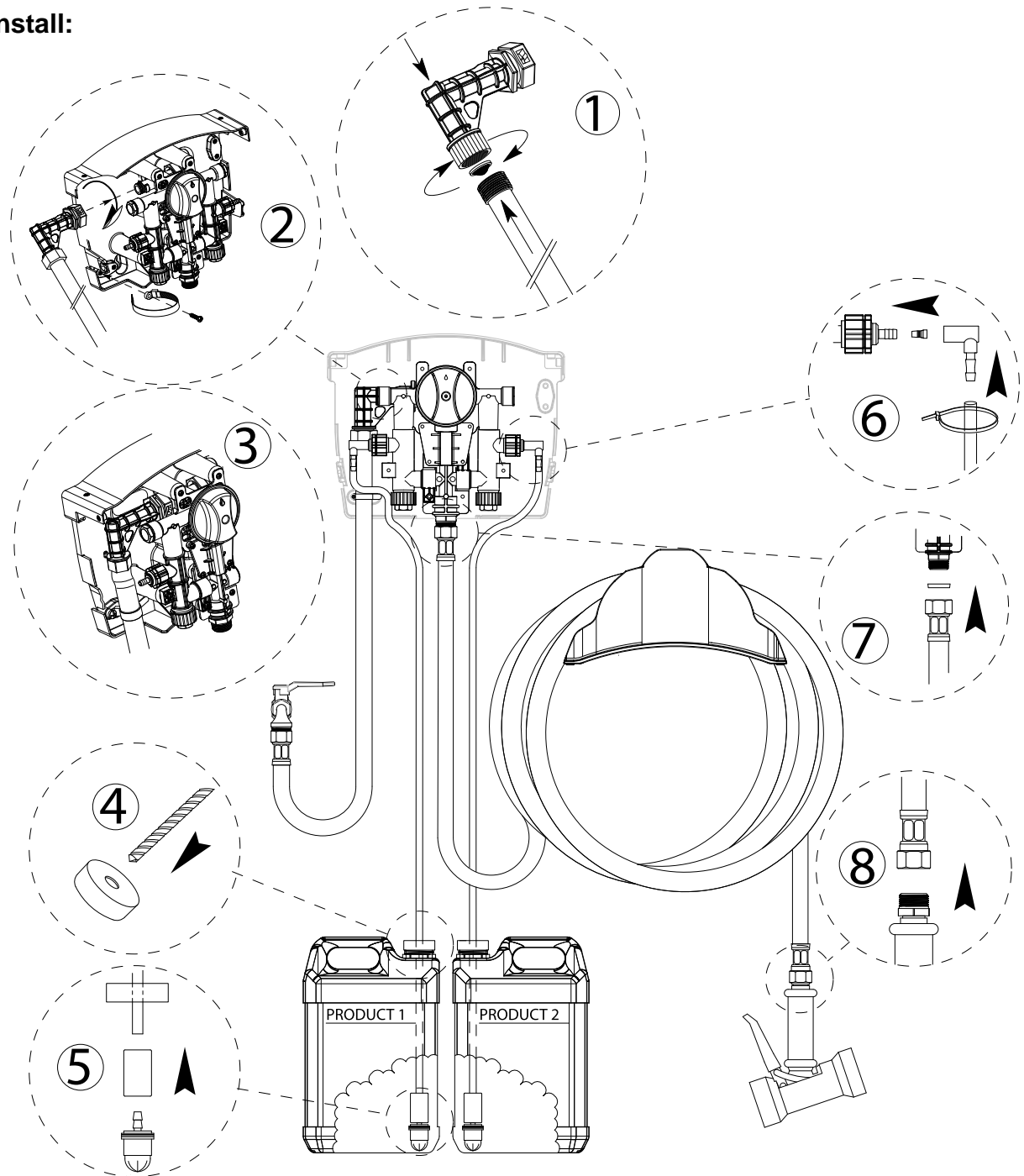

Figure 3 – Installation

1. Disconnect the 90° water inlet from the station by rotating it 45° counterclockwise to unlock it. Then connect the water inlet hose;
2. Reconnect the 90° inlet fitting back into the CleanJet, tilting by 45° to its side, consecutively rotate 45° clockwise to lock the connection;
3. Secure the hose to CleanJet through the clamp and the screw supplied as shown;
4. Drill the top of the product container using a 3/8 drill bit;
5. Slide the cap, ceramic weight onto the bottom of the supplied product pick up tube. Connect to the foot valve as in figure above.
6. Connect the pick up tube to the CleanJet as follows:
 - a. Select the ' nozzle calibration produced according to the table to be inserted into the aspiration valve as shown in the figure;
 - b. Insert the link at 90°;
 - c. For each product, place the aspiration tube into the fitting 90° and then fix it with plastic cable tie.
7. Attach the discharge hose to ¼ Male GHT fitting at the bottom of the CleanJet;
8. Attach the dosing gun.

DILUTION RATIO CHART

The dilution ratio can be achieved by using one of the 19 supplied metering tips;

Metering tips have small openings of decreasing diameter and are distinguished by different colors.

Table 1 below shows the dilution ratio's of the various colored tips assuming chemical viscosity of 1 cps (water thin)
 (Water supply pressure and flow rates will vary so adjustments in the field may be necessary)

<p><i>The dilution ratios refer to a static pressure of 50PSI with products having a viscosity of 1 cps</i></p>	<p><i>Black Venturi 2.5 GPM</i></p>
-----------------------------------------------------------------------------------------------------------------	-----------------------------------------

	Tip color:	Oz/Gal	gr/lit	%	Ratio
STANDARD MEASUREMENT TIP	No tips	24.8	186	18.6	5:1
	Grey	24.5	183	18.3	5:1
	Black	24.4	183	18.2	5:1
	Beige	20.9	156	15.6	6:1
	Red	15.2	114	11.4	9:1
	White	10.2	76	7.6	12:1
	Blue	8.4	63	6.3	15:1
	Tan	6.5	49	4.9	20:1
	Green	4.4	33	3.3	32:1
	Orange	4.0	27	2.7	36:1
	Brown	2.6	19.6	2	50:1
	Yellow	2.0	16.5	1.6	64:1
	Acqua	1.8	13.4	1.3	70:1
	Purple	1.0	6.6	0.6	128:1
	Pink	0.50	3.4	0.3	256:1
Transparent	No drill				

ULTRAFINE TIP	Lime	0.40	2,6	0.26	320:1
	Burgundy	0.35	2,8	0.28	365:1
	Pumpkin	0.30	2,2	0.22	425:1
	Copper	0.25	1,8	0.18	512:1

Table 1 – The dilution values given in this table are measured at a flow rate of 8 gpm and a supply pressure of 50psi with a delivery hose of 15.24 m (50 ft).

The values in the table should be considered only as a reference, as they are dependent on many variables such as water flow rate, pressure, chemical viscosity, temperature of the water etc.

To obtain a proper dilution it is recommended to perform the calibration as follows:

1. Fill a graduated container with the chemical product.
2. Using the Table 1, select and insert the metering tip closest to the desired dilution ratio for the product.
3. Insert the suction hose into the graduated container.
4. Select the product to be calibrated by turning the selector to the left or to the right.
5. Activate the spray gun and discharge into a container until the suction and delivery hoses are completely full and free of air (check for air bubbles at the input and for a steady output stream).
6. Mark the level in the graduated container.
7. Turn on the spray gun to the maximum and discharge into a 1 liter or 1 gallon container (or other volumes considering the proportion).
8. Turn off the spray gun when the container is completely filled.
9. Read the amount of product in the graduated container.
10. The difference of level between the point 8 and 5 indicates the amount of mixed product per gallon.
11. Repeat the calibration procedure for the other product.

A transparent metering tip is also provided without a pre-drilled opening. This tip can be manually drilled to obtain a customized degree of dilution.

Operation

The CleanJet allows the dilution of chemical products with water without using an electrical or other power source. The only energy required is the pressure of the water passing through a venturi which aspirates a metered chemical into the flow of water through the venturi.

When the installation is properly completed, follow these steps:

1. Turn on the water supply
2. Select the desired cleaning phase
 - Selector facing up "OFF"
 - Selector facing right "PRODUCT N° 1"
 - Selector facing down "RINSE"
 - Selector facing left "PRODUCT N° 2"
3. Activate the spray gun
4. Shut off the water supply when not in use

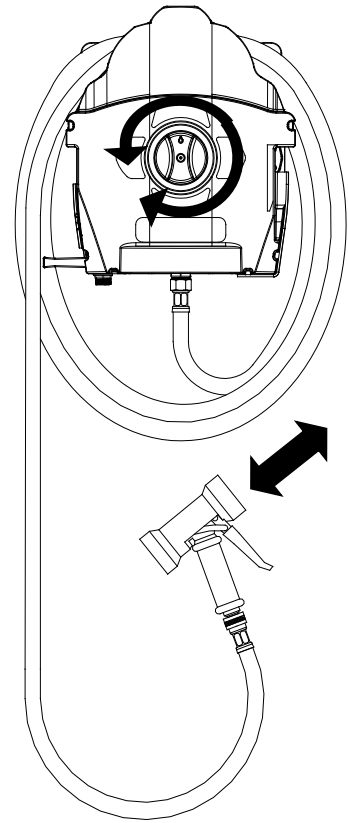

Accessories & Options:

The CleanJet is available with the Trigger gun 410 0001 and the lance 410 0002.

The lance is available with the air trigger 410 0007
 The lance is available with the air trigger 410 0008
 The lance is available with the 34 mm carbide bitting 400 0048
 The lance is available with the 34 mm lance 410 0002 not shown



MAINTENANCE

ITEM	CAUSE	MAINTENANCE
Water supply filter	Limestone deposits on the screen	Replace
	Debris or solids on the screen	Clean with water or replace
Venturi	Limestone deposits	Clean or replace (Warning: do not use tools to remove the lime deposits because you can affect the functioning of the venturi; only use anti lime products)
	Congealed product	Clean with water
Non-return valves	Worn	Replace
	Congealed product	Clean if possible or Replace
Foot filters	Worn	Replace
	Congealed product	Clean if possible or Replace

TROUBLESHOOTING GUIDE

PROBLEM	CAUSE	REMEDY
No flow	No water supply	Open the water supply outside tap
		Select product or rinse
		Turn on the spray gun
	Clogged hydraulic parts	Check the water supply filter (input station)
Check the venturi		
Product is not mixed or not dosed correctly	The foot filter is clogged	Clean or replace the filter
	The calibration nozzle is clogged	Clean or replace the nozzle
	Insufficient water pressure	A minimum pressure of 22PSI is required for correct operation; if the pressure is not correct, contact a plumber
	The chemical product container is empty	Refill or change the chemical product container
	The suction hose is not properly connected to the elbow fitting	Check that the suction hose is properly connected to the fitting, use a clamp for a better grip
	The suction hose is crimped somewhere	Check that the suction hose is properly positioned
	Debris or Solids in the venturi	Clean with water or compressed air (Warning: do not use tools to remove the lime deposits because you can affect the functioning of the venturi; only use anti lime products)
Concentration too high	The nozzle is not fully inserted or Wrong metering tip	Check that the nozzle is securely plugged into the non return valve or select a smaller metering tip
The chemical product container fills with water.	The non return valve is clogged or worn	Clean or replace the non return valve

Terms & Conditions

Company warrants its Goods to be free from material defects in material and workmanship for a period of one year except: i. when Goods have been modified following delivery and/or subject to improper handling, storage, installation, operation, or maintenance unless those modifications have been authorized in writing by Seller. ii. when an item is purchased by Company as a component part of the Goods, except to the extent to which such item or items are covered by the warranty, if any, of the original manufacturer. iii. when an item which is a component part of the product has been furnished by Buyer. iv. no warranty of a component part shall extend beyond the warranty period of the device in which such component part is incorporated. b. There is no implied warranty of merchantability or of fitness for particular purpose and there are no warranties of any nature except as set forth in paragraph 3 herein. Any claim by Buyer made pursuant to Company's warranty must be made in writing. Company shall have the right to inspect the Goods claimed to be defective and shall have the right to determine the cause of such alleged defect. All Goods replaced or repaired by Company under its warranty shall be replaced or repaired F.O.B. Company's facility. Buyer must notify Company, in writing, within fifteen (15) days from receipt of Goods of any obvious defect in the product, or shortages, or Company shall have no obligation to correct such defect. Company shall have the option of re-inspection at Buyer's plant or its own before allowing or disallowing Buyer's claim. Defects that do not impair service shall not be a cause for rejection or recovery under any warranty. Buyer assumes full responsibility for the use and application of the product. Buyer accepts Company's design and material selection and specifications in placing this order unless other specifications are agreed to in writing by both parties prior to the manufacture of Goods by Company. Statements and data relating to Products on Seller's literature and website are not intended to define the performance of the product in actual usage or in combination with other equipment or processes. These statements should not be used by Customer solely as an indication of performance or suitability for specific applications or uses.

THE ABOVE WARRANTIES ARE THE SOLE AND EXCLUSIVE WARRANTIES MADE BY SELLER WITH RESPECT TO ALL PRODUCTS AND SERVICES.

Components and spare parts such as O-rings, squeeze tubes, roller blocks and other plastic components are considered to be wear parts and are not warranted. Seller shall have no warranty or liability for product that was damaged during shipment, product that is not being used in its recommended use, product that is not operated in accordance with the operating manual and procedures, product that was not properly installed, product used in a manner that is inconsistent with its designed purpose, product that is subject to a power surge or similar event, products that fail due to usage of a non Lavo Solutions replacement or spare part or product that was not maintained in accordance with recommended maintenance programs.

For full terms and conditions, please visit:
<http://lavosolutions.com/LAVO-T&C-02-2018.pdf>

Lavo Solutions, LLC
23192 Verdugo, Suite #D
Laguna Hills, CA 92653

O: 949-377-1250
W: www.lavosolutions.com