 Connected

Dispensing Solutions



Simple.
Clean.
Connected.

Why invest in Connected Equipment?

- Immediate ROI. Systems can cost less than 1 service call
- Increase efficiency and revenue
- Maximize account profitability
- Reduce service costs up to 30%
- Immediate email alert notifications of warnings, issues and errors
- 100% asset visibility
- Significantly improve customer response time (proactive vs reactive)

Overview

- Total overview of formulas, chemical injections and usage, plant efficiency and flow rates
- Clear and consistent documentation and reporting capabilities
- Encrypted and secured data and software

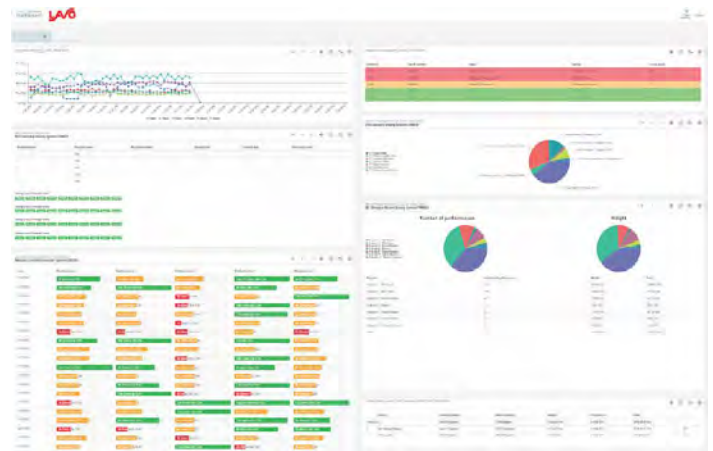

Custom Dashboard

Reporting features

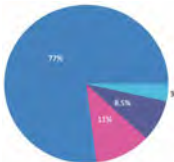

Product consumption & low level alarms



Inventory control and facility overviews

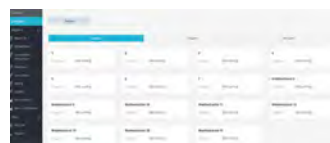

Live detailed washer and tunnel views



Asset visibility map



Firehouses



Education



Nursing / Senior Care



Hotels / Motel OPL Laundry



Healthcare Co-Op



Industrial Linen & Uniform



Sport / Fitness

Connected OPL - GoLink Pro

LAVO Simple.
Clean.
Connected.

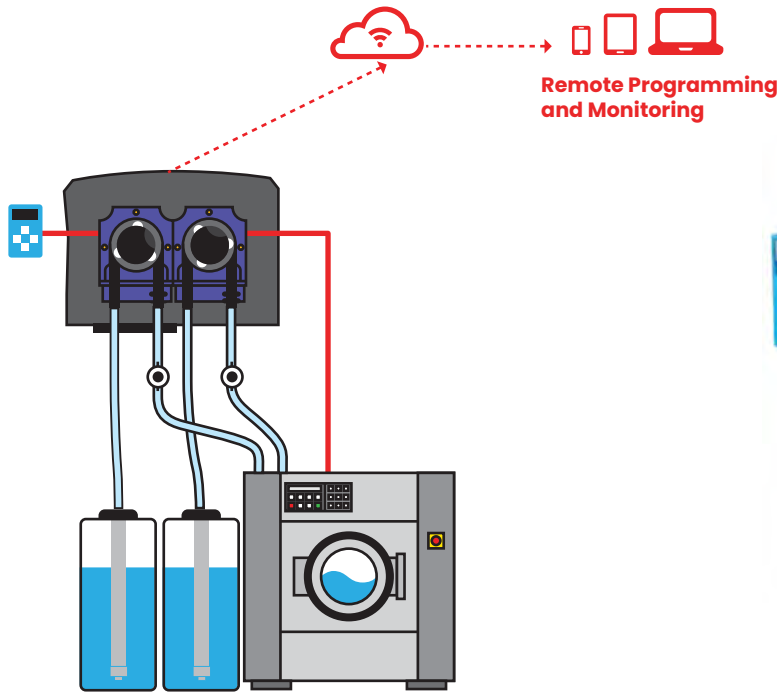

Key Features

- Controlled dosing and proof of delivery via flow meter technology for warewash and laundry
- 24/7 remote monitoring and access
- Remote calibration, programming and troubleshooting
- Cellular connectivity for uninterrupted service and safest data transmission
- Data encryption is standard
- Installation hardware included
- Optional keypad for programming
- Optional third chemical pump

Specifications

- Pump output: 10 oz / min
- Voltage 120/240 VAC 50/60Hz
- Tubing recommendation: 1/4" OD
- Squeeze tube / flow meter fittings: 1/4" OD compression
- IP65 rated enclosure
- Isolated signal inputs 24VDC up to 240VAC
- Cellular based 4G / LTE
- Recommended for washers up to 150lb



Firehouses



Education



Nursing /
Senior Care



Hotels / Motel
OPL Laundry



Sport / Fitness

Connected OPL – OPLink Pro

LAVO Simple.
Clean.
Connected.

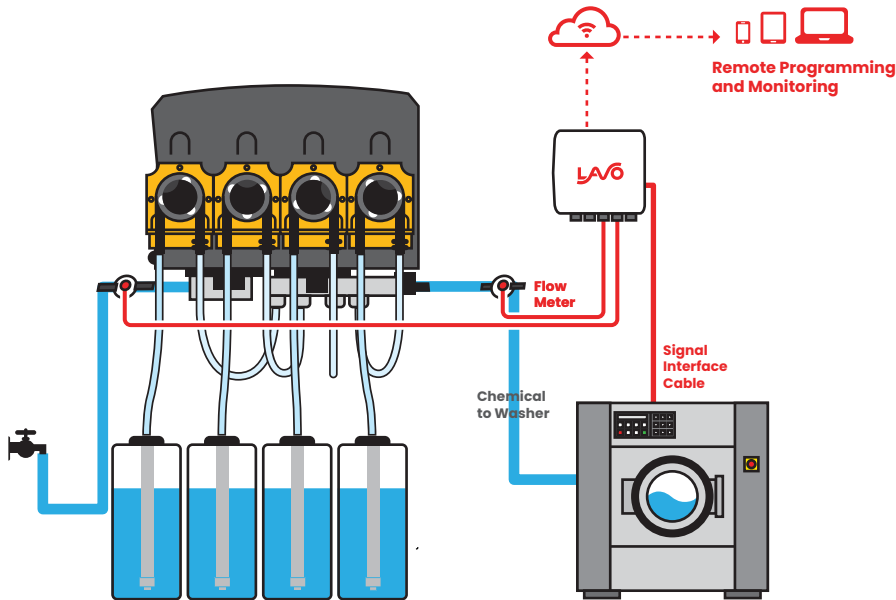

Key Features

- Complete system with controlled dosing and proof of delivery via flow meter technology
- Integrated signal interface
- 24/7 remote monitoring and access
- Remote calibration, programming and troubleshooting
- Cellular connectivity for uninterrupted service and safest data transmission
- Data Encryption is standard
- Integrated water valve, flush manifold and flow meter
- Installation hardware included
- Option for up to 6 chemical pumps

Specifications

- Pump Output up to 68oz / min
- Voltage 120/240 VAC 50/60Hz
- Tubing recommendation: 3/8 ID (inlet / outlet)
- Squeeze Tube / Flow Meter Fittings: 3/8" barbed compression
- IP65 rated enclosure
- Isolated inputs 24VDC up to 240VAC
- Cellular based 3G / LTE
- Recommended max washer capacity: 450lbs



Firehouses



Education



Nursing /
Senior Care



Hotels / Motel
OPL Laundry



Sport /Fitness

Connected
OPL- MultiLink Pro

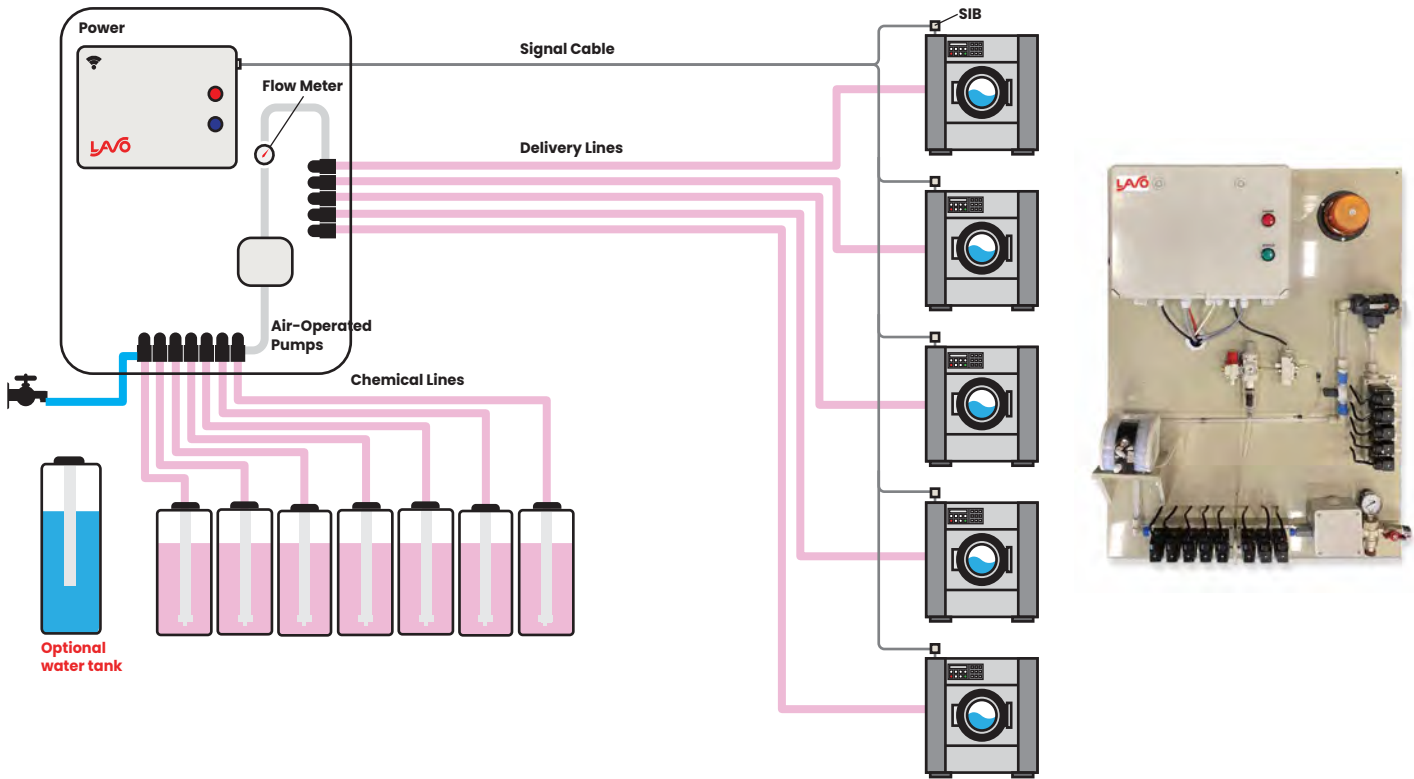

Key Features

- Controlled dosing and proof of delivery via flow meter technology
- Connects up to 5 washers and 8 chemicals on one panel
- 24/7 remote monitoring and access
- Remote calibration, programming and troubleshooting
- Cellular connectivity for uninterrupted service and safest data transmission
- Data encryption is standard
- Air assisted flush available
- Installation hardware kits available

Specifications

- Pump Output: 1.3 gal/min (5 L/min)
- Voltage 120/240 VAC 50/60Hz
- Tubing recommendation: 3/8 ID (inlet / outlet)
- Isolated inputs 24VDC up to 230 VAC
- IP65 rated electronics enclosure
- Pneumatic or electromagnetic pumps
- Cellular based 3G / LTE
- Recommended max washer capacity: 450lbs
- Water connection: 1/2" hose barb
- Air connection: 1/4"OD push to connect



Firehouses



Education



Nursing /
Senior Care



Hotels / Motel
OPL Laundry



Sport /Fitness

Industrial Laundry Solutions

Wash Extractors



Key Features

- Controlled dosing and proof of delivery via flow meter technology
- Connects up to 15 wash extractors
- 24/7 remote monitoring
- Remote calibration, programming and troubleshooting
- Cellular connectivity for uninterrupted service and safest data transmission
- Free standing cabinet or wall mounted panel options

Specifications

- Pump Output up to 300oz / min
- Voltage: 120/240 VAC 50/60 Hz
- Tubing Recommendation: 3/8" ID (inlet / outlet)
- Isolated inputs 24 VDC up to 230 VAC
- Cellular based -4G / LTE
- Pneumatic or electromagnetic pumps
- Recommended maximum washer capacity - 900 lbs.
- Water Connection - 1/2" hose barb
- Air Connection - 1/4" OD Push to Connect



Education



Nursing /
Senior Care



Hotels / Motel
OPL Laundry



Healthcare
Co-Op



Industrial
Linen & Uniform

Connected

Industrial Laundry Solutions

**Simple.
Clean.
Connected.**

Key Features

- Controlled dosing and proof of delivery via flow meter technology
- Simultaneously dose tunnel and washer extractors from a single cabinet
- Connect up to 7 injection points
- Connect up to 15 wash extractors
- 24/7 remote monitoring and access
- Remote calibration, programming and troubleshooting
- Cellular connectivity for uninterrupted service and safest data transmission
- Free standing cabinet

Specifications

- Pump Output up to 300 oz / min
- Voltage: 120/240 VAC 50/60 Hz
- Tubing Recommendation: 3/8" ID (inlet / outlet)
- Isolated inputs 24 VDC
- Cellular based - 4G / LTE
- Pneumatic pumps & valves
- Recommended maximum tunnel capacity - 250 lb pockets
- Water Connection - 3/4" hose barb
- Air Connection - 1/4" OD Push to Connect

Education

**Nursing /
Senior Care**

**Hotels / Motel
OPL Laundry**

**Healthcare
Co-Op**

**Industrial
Linen & Uniform**

 Connected

Warewash- GoLink Pro

LAVO Simple. Clean. Connected.

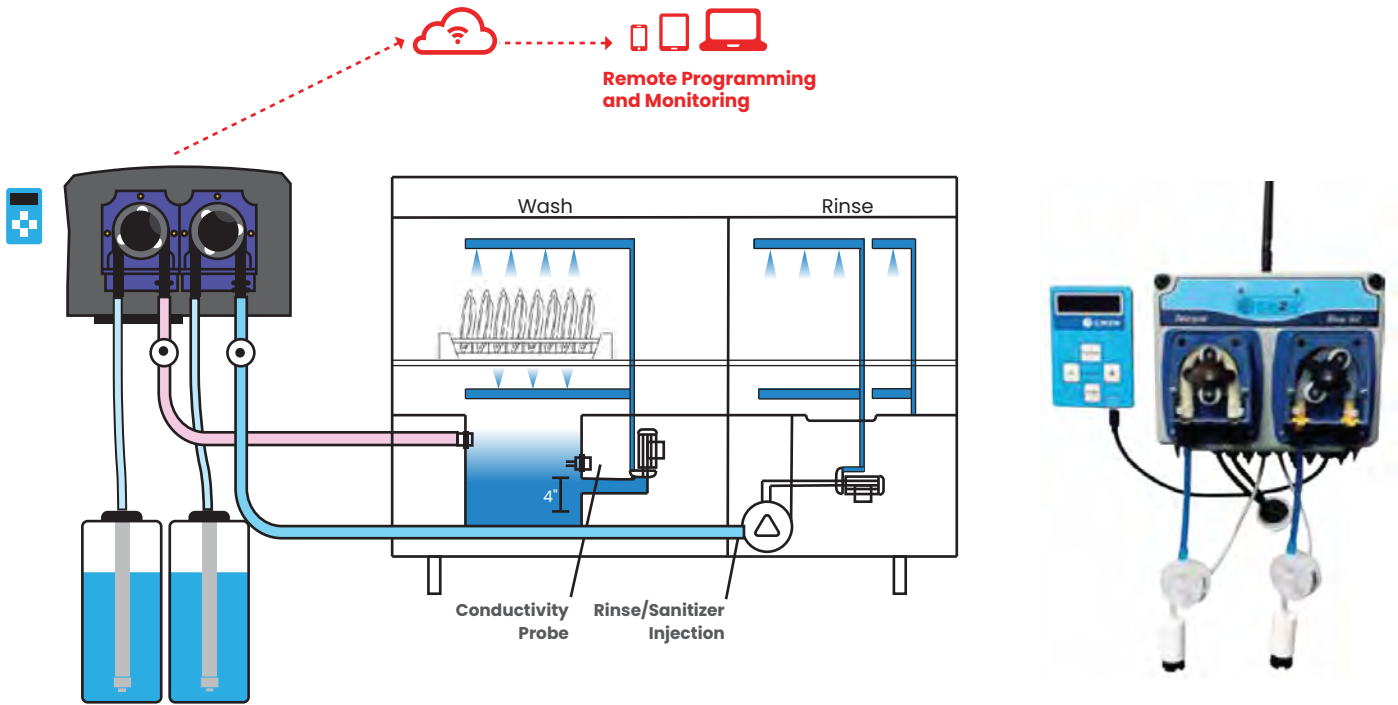

Key Features

- Exact dosing and proof of delivery via flow meter technology
- 24/7 remote monitoring and access
- Remote calibration, programming and troubleshooting
- Cellular connectivity for uninterrupted service and safest data transmission
- Data encryption is standard
- Installation hardware included
- Optional keypad for programming
- Optional third chemical pump

Specifications

- Pump Output: 10oz / min
- Voltage 120/240 VAC 50/60Hz
- Tubing recommendation: 1/4 OD
- Squeeze Tube / Flow Meter Fittings: 1/4" compression
- IP65 rated enclosure
- Isolated inputs
- Cellular based 4G / LTE
- Recommended for most dish machines sizes and styles



Supermarket



Restaurant



Church and Banquet



Convenience Store



Catering & Food Service

Connected Fluid Monitoring

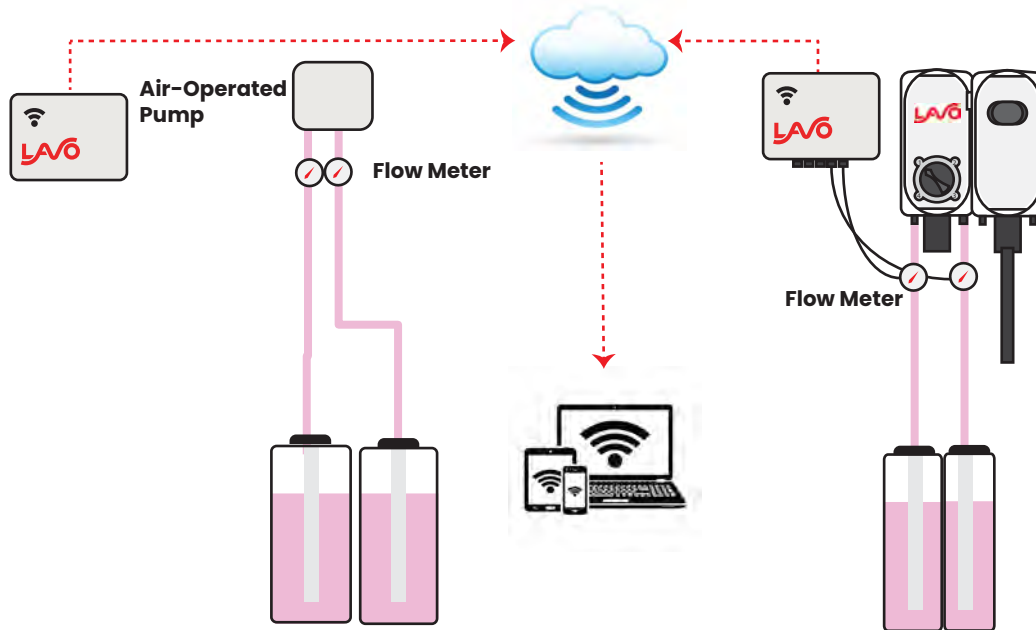

Key Features

- Controlled dosing and proof of delivery via flow meter technology
- Used to monitor fluid flow and consumption data on various dispensing equipment.
- Ability to retrofit to most existing installations
- Up to 7 products or 6 products + 1 water meter
- 24/7 remote monitoring and access
- Remote calibration, programming and troubleshooting
- Simple, easy installation
- Cellular connectivity for uninterrupted service and safest data transmission
- Dilution rates displayed in % for ratio validation
- Data encryption standard

Specifications

- Low Flow Meter: .05 oz /min (15ml/min) to 30oz/min (900ml/min)
- High Flow Meter: 2.5oz/min (70ml/min) to 170 oz/min (5000 ml/min)
- Voltage 120/240 VAC 50/60Hz
- Tubing recommendation: 1/4"OD
- Cellular based 3G / LTE



Firehouses



Education



Nursing /
Senior Care



Hotels / Motel
OPL Laundry



Healthcare
Co-Op



Industrial
Linen & Uniform



Sport / Fitness

 Connected

Warewash Solutions

LAVO Simple. Clean. Connected.

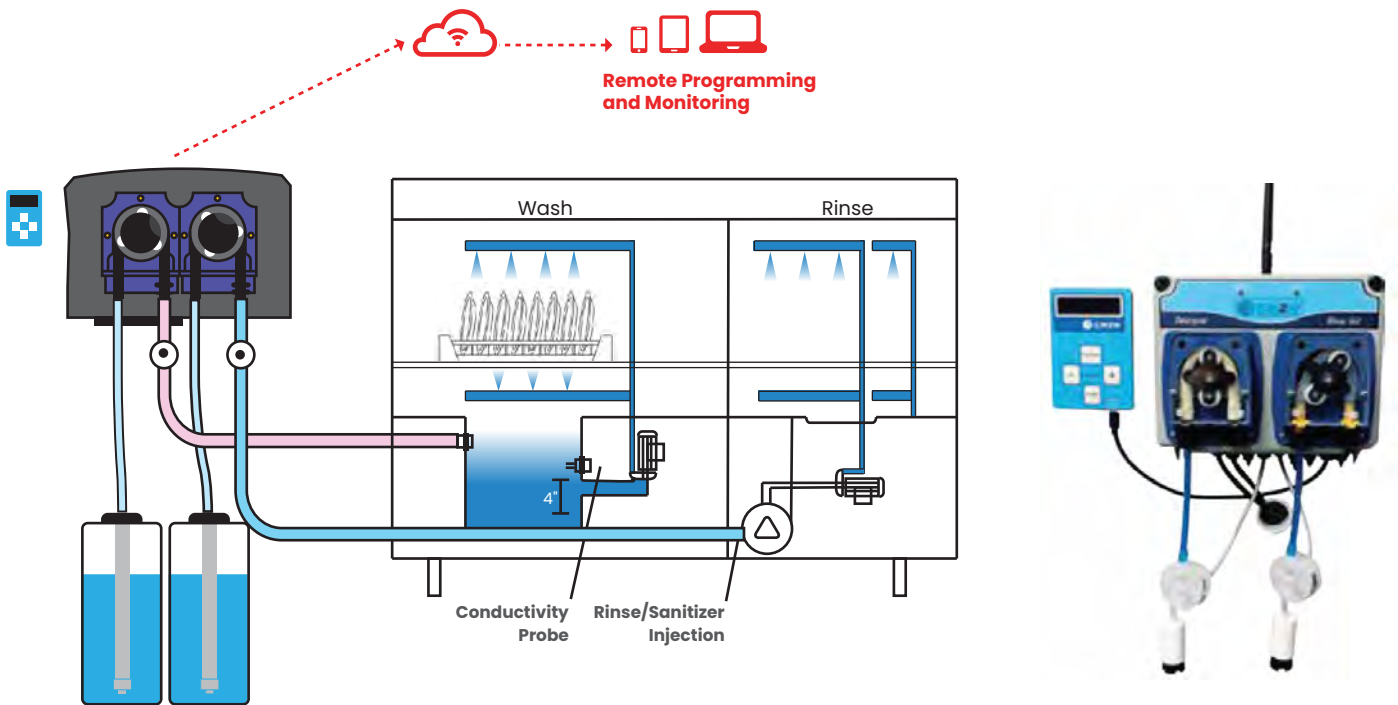

Key Features

- Exact dosing and proof of delivery via flow meter technology
- 24/7 remote monitoring and access
- Remote calibration, programming and troubleshooting
- Cellular connectivity for uninterrupted service and safest data transmission
- Data encryption is standard
- Installation hardware included
- Optional keypad for programming
- Optional third chemical pump

Specifications

- Pump Output: 10oz / min
- Voltage 120/240 VAC 50/60Hz
- Tubing recommendation: 1/4 OD
- Squeeze Tube / Flow Meter Fittings: 1/4" compression
- IP65 rated enclosure
- Isolated inputs
- Cellular based 3G / LTE
- Recommended for most dish machines sizes and styles

Spare Parts

- Squeeze tubes - EPDM, Viton, Silicone
- 24 VDC motor roller
- Roller Assembly



Supermarket



Restaurant



Church and Banquet



Convenience Store



Catering & Food Service