



INSTRUCTION MANUAL

TABLE OF CONTENTS

Safety	2
Product Diagram	3
Product Setup & Use	4
Technical Specs	5
Maintenance	6
Terms & Conditions	7

Introduction

Lavo's SimpleSink is a robust, water driven dispenser that mixes chemicals with the turn of a knob. With the SimpleSink, you are sure to get consistent mixtures of chemical with every use. The dispenser offers Flex Gap and Air Gap options to fit all city requirements.

Safety

 **READ THE FOLLOWING WARNINGS BEFORE PROCEEDING TO INSTALL OR DO MAINTENANCE WORK ON THIS DILUTION UNIT.**

- **Optimum water supply pressure is 40 PSI. Max. 100 PSI; Min. 20 PSI**
- **Max. temperature 140° F**
- Fittings have been tested for use with the most common liquid detergents mixed with water. Check that the detergent used is compatible with brass and polypropylene.
- Install the unit near a connection point for the water supply and above the sink in such a way that the activation valve is accessible.
- Mount the unit to facilitate cleaning and so the plumbing fittings are accessible for replacing metering tips and routine maintenance.

 **WARNING:** Always follow necessary safety procedures, including the use of adequate Personal Protective Equipment.

 **WARNING:** When servicing this dispenser, always shut off the water supply line.

 Failure to follow the instructions in this manual can cause damage to the unit or to the property, and can possibly cause injury.

 **TO PREVENT SIPHONING AND TO COMPLY WITH ASME A112.1.2, INSTALL THE SimpleSink WITH THE END OF THE OUTLET TUBE A MINIMUM 4" ABOVE THE FLOOD LEVEL OF THE SINK OR OTHER FIXED CONTAINER.**

Product Diagram

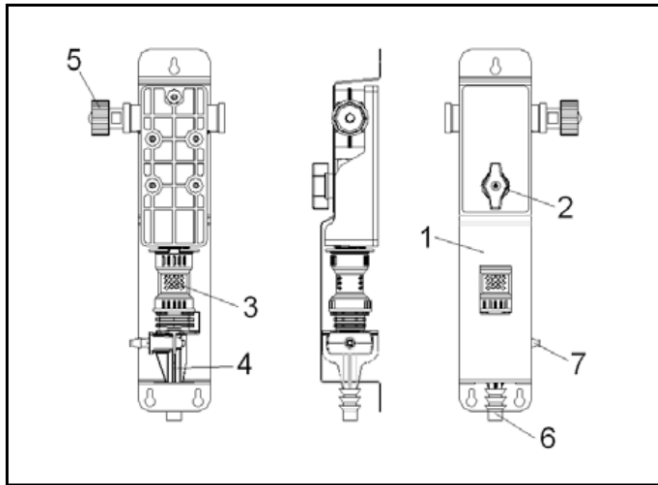

PN: 100-SS-14AG / SimpleSink 1 PRODUCT 4 GPM Air Gap

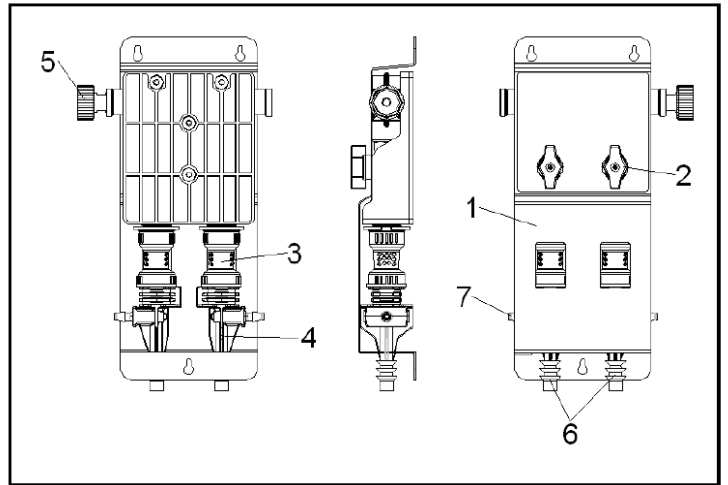

PN 100-SS-24AG / SimpleSink 2 PRODUCT 4 GPM Air Gap

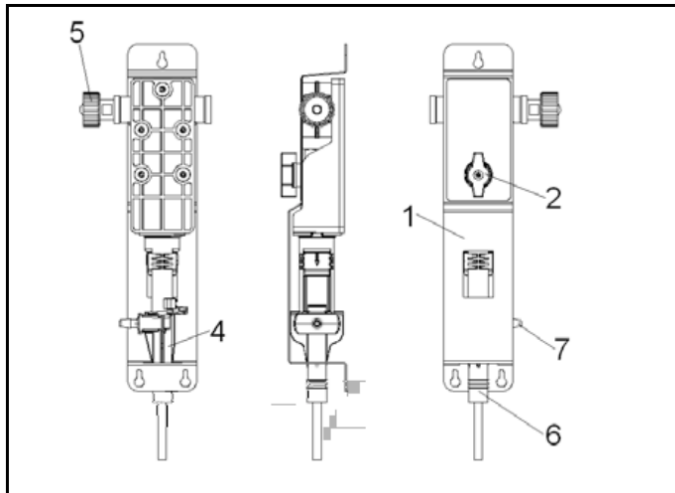

PN: 100-SS-14 SimpleSink 1 PRODUCT 3.5GPM Flex Gap

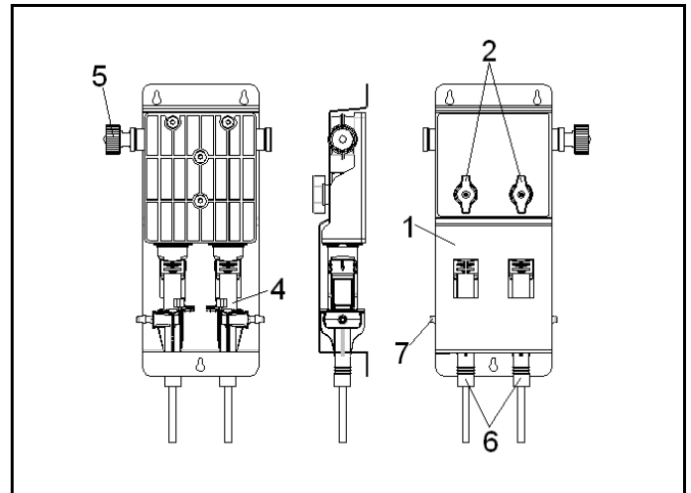

PN: 100-SS-24 / SimpleSink 2 PRODUCT 3.5GPM Flex Gap

Number	Description
1	Satin-finish STAINLESS STEEL cover
2	On/Off knob
3	Flex-Gap, Air Gap
4	Water Valve
5	3/4" GHT Swivel Stem
6	Connection for outlet hose – 3.5/4GPM
7	Barb for pick up hose 1/4" ID – 3/8" OD

Product Setup & Use

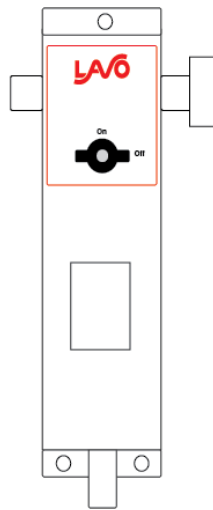
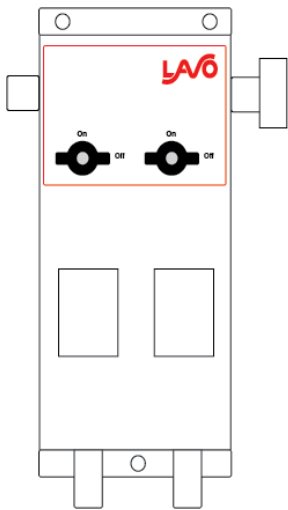

1. Position the SimpleSink on a vertical wall and make sure that it is within arms reach from an operator, and within 6ft of a water source.
2. Mark the position of the mounting holes on the wall.
3. Drill two 1/4" diameter holes at the points marked on the wall.
4. Put the anchors supplied into these holes and screw in the screws without completely tightening
5. Mount the unit and secure tightly.

Plumbing

1. Insert the water inlet screen into the 3/4" GHT water inlet swivel.
2. Connect the water supply line to the female swivel on the top right of the SimpleSink. Make sure the connection is securely fastened.
3. Once you have decided on a metering tip, insert it into the barb fitting.
4. Install the pick up hose (1/4" ID – 3/8" OD) on to the venturi.
5. Install the discharge tube over the outlet of the venturi.
6. Position the delivery hose above the sink.
7. Install the weight onto the end of the pick up tube, install the foot valve and slide the weight until flush with the foot valve.
8. Place the pick up tube into the product container.

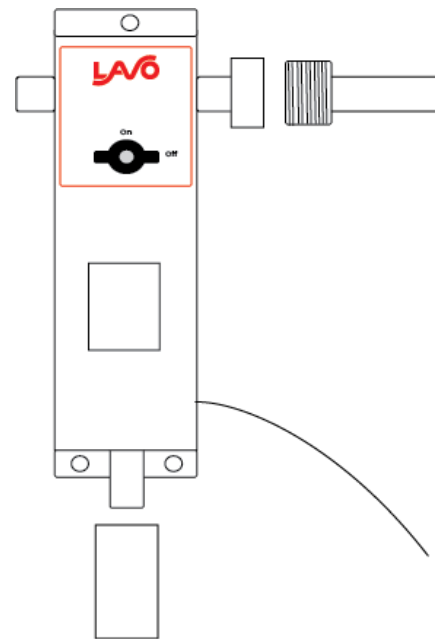

 **Warning: The difference in height between the bottom of the product container and the SimpleSink nozzle connector should not exceed 6ft**

 **Warning: The product must be below the SimpleSink to prevent siphoning.**

 **Warning: The end of the delivery hose must be above the level of the product to be mixed to prevent siphoning.**

 **Warning: The air gap outlet tubes must be installed with flow restrictor rings closest to the dispenser**

Technical Specs—FlexGap

Dynamic pressure upstream of the SimpleSink Flex-Gap

1GPM	14.5 PSI	29 PSI	45.5 PSI
Flow Rate in GPM	0.7	1.3	1.7
3.5GPM	14.5 PSI	29 PSI	45.5 PSI
Flow Rate in GPM	1.6	2.7	3.4

Dynamic pressure upstream of the SimpleSink Air Gap

1GPM	14.5 PSI	29 PSI	45.5 PSI
Flow Rate in GPM	0.7	1.2	1.5
4GPM	14.5 PSI	29 PSI	45.5 PSI
Flow Rate in GPM	2.1	2.9	3.5



Dilution Chart Note: Dilutions will vary. Tested at 40PSI with water products.

FLEX GAP

		4 GPM	
Standard Metering Tip	Tip Color	Oz / Gal	Ratio
	No Tip	22	6:1
	Grey	21	6:1
	Black	20	6:1
	Beige	14	9:1
	Red	9	12:1
	White	6	20:1
	Blue	5	24:1
	Tan	4	32:1
	Green	2	64:1
	Orange	1.8	70:1
	Brown	1.5	80:1
	Yellow	1.3	96:1
	Aqua	1.0	128:1
	Purple	0.5	256:1
Pink	0.4	320:1	
Clear	No Hole		

Ultralean Tip	Lime	0.25	512:1
	Burgundy	0.20	625:1
	Pumpkin	0.15	833:1
	Copper	0.10	1250:1

AIR GAP

		4 GPM	
Standard Metering Tip	Tip Color	Oz / Gal	Ratio
	No Tip	16	6:1
	Grey	16	8:1
	Black	13	10:1
	Beige	11	12:1
	Red	9	15:1
	White	6.2	20:1
	Blue	6	22:1
	Tan	5	25:1
	Green	3.2	36:1
	Orange	2.4	50:1
	Brown	2	64:1
	Yellow	1.8	70:1
	Aqua	1.5	83:1
	Purple	1.0	128:1
Pink	0.5	256:1	
Clear	No Hole		

Ultralean Tip	Lime	0.25	512:1
	Burgundy	0.17	769:1
	Pumpkin	0.13	1000:1
	Copper	0.09	1429:1

*The SimpleSink provides flow rates shown above when mixing one chemical.

Maintenance

1. Periodically check for buildup or debris foot valve.
2. Periodically check and if necessary, clean the washer filter in the swivel stem.
3. Periodically remove any lime build-up. To clean the Venturi properly replace the product to be mixed with a suitably diluted delimer product and turn the tap to draw the product through the system.

Troubleshooting

Problem	Cause	Solution
System does not dispense solution	<ol style="list-style-type: none"> 1. Water inlet strainer is clogged 2. Too much water pressure 3. Insufficient water pressure 4. The venturi is clogged 5. Activation valve is clogged by debris 	<ol style="list-style-type: none"> 1. Clean it or replace if necessary 2. Use a water pressure regulator in case of more than 100PSI 3. 20PSI is the minimum required pressure. 4. Soak venturi in hot water and inspect visually, gently removing debris. Replace assembly if needed. 5. Soak the valve assembly in a solution of hot water and limescale remover. Replace assembly if needed.
Water flow won't stop	<ol style="list-style-type: none"> 1. Activation valve is clogged by debris 	<ol style="list-style-type: none"> 1. Soak the valve parts and valve seat in delimer to clean. Replace them if necessary
Activation valve is leaking	<ol style="list-style-type: none"> 1. Valve cap not tight enough to seat 2. Not properly positioned 	<ol style="list-style-type: none"> 1. Firmly hand tighten the valve cap until leak stops. 2. Reposition the valve or change it if necessary
Connections and end cap are leaking	<ol style="list-style-type: none"> 1. Missing o-ring in the connection fitting and / or end cap 2. O-ring in the connections or end cap are damaged 	<ol style="list-style-type: none"> 1. Apply the o-ring or replace the entire part 2. Replace the o-rings or replace the entire end cap
Flex Gap is leaking	<ol style="list-style-type: none"> 1. Flexible membrane is damaged 	<ol style="list-style-type: none"> 1. Replace the Flex Gap
Air gap is spraying out and/or leaking	<ol style="list-style-type: none"> 1. Limescale film or dirt on the A-gap's upper nozzle 2. Venturi coated with limescale or dirt 3. There is a buildup or clog in the discharge hose 4. Discharge hose is above the dispenser 	<ol style="list-style-type: none"> 1. Soak in hot water and delimer to remove buildup. Replace if necessary 2. Soak in hot water and delimer to clean. Replace it if necessary 3. Clean the hose to eliminate restriction 4. Make sure the discharge hose dispenses below the dispenser insuring no back pressure
Improper concentration of chemical or no suction	<ol style="list-style-type: none"> 1. Insufficient water pressure 2. Metering tip clogged 3. Foot valve clogged 4. Venturi clogged 5. Air leak in chemical pick up tubing line 6. Product is too thick 7. Product container is too far from the system 8. Excess concentration 	<ol style="list-style-type: none"> 1. 14PSI is the minimum working pressure. 2. Replace tip 3. Soak in hot water, hand clean or change it 4. Soak in hot water or delimer to clean. Replace it if necessary 5. Check the entire line. Replace the tubing check the connections and cable tie 6. Change the pick up hose. Switch to a bigger diameter. (need ¼ x 5/16 coupler) 7. The standard installation is positioning the tank under the system, 5ft max 8. Tip is not the correct one or not inserted fully.
System continues to draw chemical after the valve is closed	<ol style="list-style-type: none"> 1. Chemical tank is positioned higher than the dispenser causing siphoning 	<ol style="list-style-type: none"> 1. Move chemical container below the dispenser discharge point

Terms & Conditions

Company warrants its Goods to be free from material defects in material and workmanship for a period of one year except: i. when Goods have been modified following delivery and/or subject to improper handling, storage, installation, operation, or maintenance unless those modifications have been authorized in writing by Seller. ii. when an item is purchased by Company as a component part of the Goods, except to the extent to which such item or items are covered by the warranty, if any, of the original manufacturer. iii. when an item which is a component part of the product has been furnished by Buyer. iv. no warranty of a component part shall extend beyond the warranty period of the device in which such component part is incorporated. b. There is no implied warranty of merchantability or of fitness for particular purpose and there are no warranties of any nature except as set forth in paragraph 3 herein. Any claim by Buyer made pursuant to Company's warranty must be made in writing. Company shall have the right to inspect the Goods claimed to be defective and shall have the right to determine the cause of such alleged defect. All Goods replaced or repaired by Company under its warranty shall be replaced or repaired F.O.B. Company's facility. Buyer must notify Company, in writing, within fifteen (15) days from receipt of Goods of any obvious defect in the product, or shortages, or Company shall have no obligation to correct such defect. Company shall have the option of re-inspection at Buyer's plant or its own before allowing or disallowing Buyer's claim. Defects that do not impair service shall not be a cause for rejection or recovery under any warranty. Buyer assumes full responsibility for the use and application of the product. Buyer accepts Company's design and material selection and specifications in placing this order unless other specifications are agreed to in writing by both parties prior to the manufacture of Goods by Company. Statements and data relating to Products on Seller's literature and website are not intended to define the performance of the product in actual usage or in combination with other equipment or processes. These statements should not be used by Customer solely as an indication of performance or suitability for specific applications or uses.

THE ABOVE WARRANTIES ARE THE SOLE AND EXCLUSIVE WARRANTIES MADE BY SELLER WITH RESPECT TO ALL PRODUCTS AND SERVICES.

Components and spare parts such as O-rings, squeeze tubes, roller blocks and other plastic components are considered to be wear parts and are not warranted. Seller shall have no warranty or liability for product that was damaged during shipment, product that is not being used in its recommended use, product that is not operated in accordance with the operating manual and procedures, product that was not properly installed, product used in a manner that is inconsistent with its designed purpose, product that is subject to a power surge or similar event, products that fail due to usage of a non Lavo Solutions replacement or spare part or product that was not maintained in accordance with recommended maintenance programs.

For full terms and conditions, please visit:
<http://lavosolutions.com/LAVO-T&C-02-2018.pdf>

Lavo Solutions, LLC
Worldwide Headquarters
23192 Verdugo, Suite #D
Laguna Hills, CA 92653

O: 949-377-1250
W: www.lavosolutions.com