



INSTRUCTION & OPERATION MANUAL

TABLE OF CONTENTS

PRE INSTALLATION

Product Diagram	3
Introduction	4
Safety	5
Operating Modes Overview	6

INSTALLATION

Mounting	7
Power & Solenoid	8
Machine Interface	9
Adjusting Flow Rates	10
Pump Time Guide	11

PROGRAMMING

Programming Commands Overview	12
Priming The Dispenser	12
Time Dosing	13
Drain Mode	16
Relay Mode	18
Auto Formula Select	19
Programming Commands	23
Troubleshooting	26
Terms & Conditions	27

Product Diagram

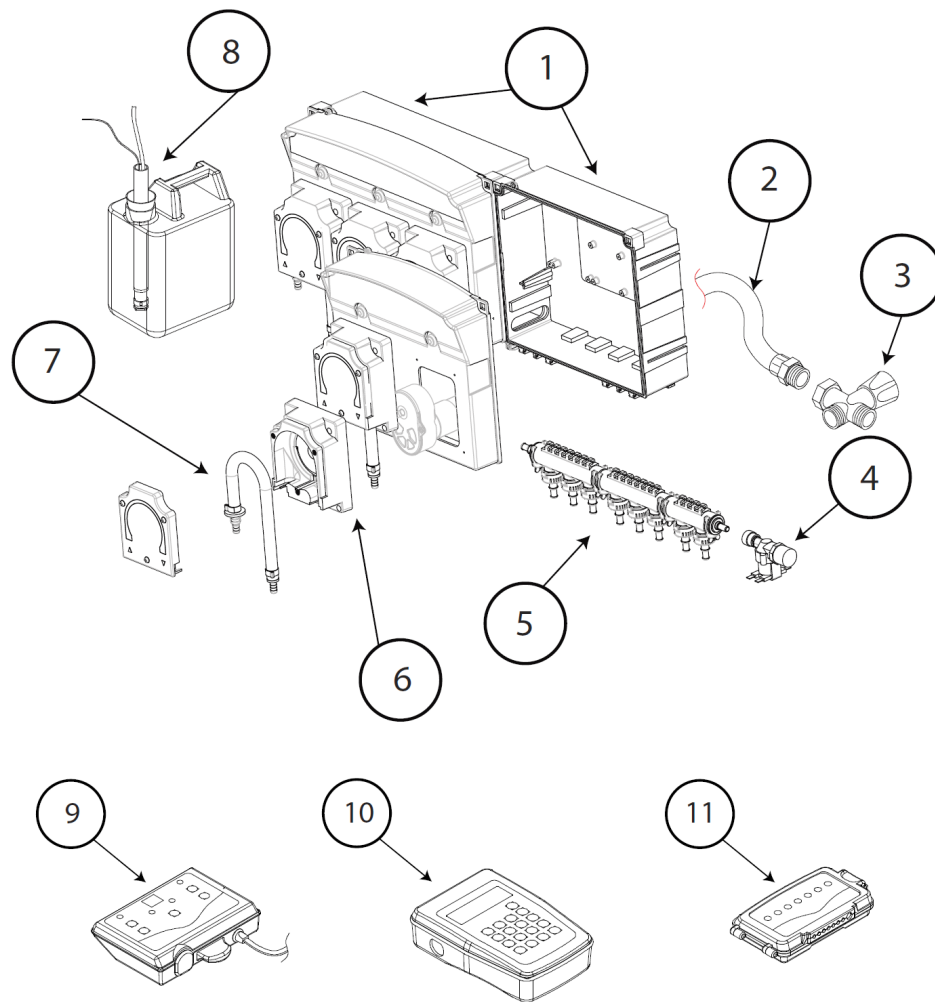

Number	Description
1	Controller Box
2	Water delivery hose (not supplied)
3	Water faucet (not supplied)
4	Solenoid valve (24 VDC) (only if optional manifold ordered)
5	Flush kit (only if optional flush manifold ordered)
6	Peristaltic pump
7	Squeeze Tube
8	Lance (optional)
9	Control console
10	Programmer (optional)
11	Level Controller

Introduction

Welcome

With the LavoWash OPL system for industrial laundry machines, you are guaranteed to fulfill the needs of all of your OPL laundry needs. This unique device offers up to 6 pumps that dose from 17 oz. to 67 oz. per minute.



Pay special attention to the warnings and to the precautions pointed out in the manual.

Check your package contents

Check	QTY	Description
	1	LavoWash OPL without flush manifold
	1	Remote Controller for Programming
	1	SIB (Signal Interface Box)
	1	Quick Start Guide
	1	Mounting kit with hardware
	1	Adhesive Velcro strip for securing the remote

Technical Specifications

Power-supply requirements	100VAC to 240VAC 50/60Hz
Maximum current absorption	100W
Flow rate of pumps	33 oz/min is factory setting (17/34/50/67 oz/min)
Signal Interface Box (SIB)	24VDC Output / 20VAC to 230VAC Inputs / 23ft cable / 6 inputs
Formula Selector	24VDC Output / 9 Formula Capacity
Class of protection	IP 65
Alarm output (optional)	Relay-type contact NC in an alarm condition, 250V 8A max

Safety

 Read this manual carefully before proceeding with the installation and starting up the LavoWash OPL system.

 The dosing unit should be connected to the power supply by means of a single-pole breaker having an opening distance equal to or greater than 3 mm.

 Check the model of the equipment purchased for the reference information contained in this manual for installing, setting and programming it.

 For all connections, refer to the diagram of the control circuit contained in this manual.

 **CAUTION:** Always follow the appropriate safety procedures, including the use of suitable means for protecting the eyes, face, hands and clothing.

 **CAUTION:** Always disconnect the equipment from the power supply before carrying out the installation or any maintenance work on it.

 LAVO Solutions LLC. works constantly to improve all its products, and reserves the right to make changes at any time without prior notice.

 Failure to follow instructions in this manual can cause damage to your equipment, or the property you are connecting to. It is important to disconnect all power prior to connecting this dispenser.

Material required for installation

- Electrical cable for connections.
- Tie-wraps to secure tubing and cables.
- PVC hose 7/16" OD x 5/16" ID (for pick-up and delivery)

 Lavo provides additional installation materials to help you with your installation.

Operating Modes Overview

Normal

- The system will accept up to 9 formulas, and each pump has optional run and delay times.
- Pumps are triggered to run from signals from the washer.
- Run and delay times are controlled by the electronics of the LavoWash OPL.
- Laundry personnel select the appropriate wash formula using the “FORMULA SELECT” key before starting the wash cycle.
- The initial signal to pumps 1 - 6 will run “level” 1. If these pumps are signaled a second time **in the same formula**, “level” 2 will run. (Assuming the signal lockout time, if programmed, has expired. Pumps 1 – 6 will accept additional signals with a change of formula number, a signal to the Load Count Pump or by pressing the RESET button.
- “Two Level” programming is possible with Pumps 1 to 6. If no level 2 is needed, it can be bypassed by not programming a pump run time for that level. The second signal will run the programmed second level.

Relay

- Laundry machines that have microprocessor controllers allow the LavoWash OPL to be programmed in relay mode. In this mode, pumps run whenever a signal is present.
- Formulas are selected at the keypad of the washer.
- The Lavo Wash OPL controller displays an “r” in the formula number window.

Drain

- The capability of programming based on Drain function adds to the versatility of the LavoWash OPL. It provides a user friendly signal interface capability to machines where customary supply signals are not present and/or in cases where the washer’s supply signals are inoperative or faulty. Drain Mode requires only one signal source.

Auto Formula Select

- The LavoWash OPL offers AFS when using the LavoWash OPL Plus remote. AFS allows you to manage which formula is dispensed based on how you program the washer. There are two modes of programming AFS: time-based and binary. In both methods, the operator does not need to worry about selecting the formula.

Installation—Mounting

 **CAUTION:** Do not install the equipment close to sources of heat. Disconnect all electricity before proceeding with the installation.

Mounting the dispenser

- Use the mounting template provided to mark the holes.
- Install the system at a height of about 5 ft from the ground
- Mount the brackets to the wall with the supplied ¼” anchor bolts (Picture 1).
- After securing the brackets in place, hang the **LavoWash OPL** System from them, as shown in the picture 2.

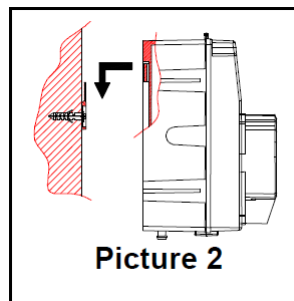
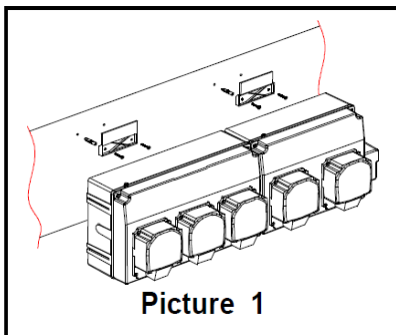

 Take time to secure the brackets to the wall correctly; Any errors in centering them would make it difficult to mount the LavoWash OPL.

 If the surface of the wall is not flat, you are able to secure the box directly to the wall by drilling through the breaking lines inside each pump box and mount the box to the wall using the supplied ¼’ anchor bolts. To maintain the IP protection rating, it is recommended to apply silicone to the screws inside the box.

Electrical—Power & Solenoid

CAUTION: Do not install the equipment close to sources of heat. Disconnect all electricity before proceeding with the installation.

CAUTION: Always disconnect the LavoWash OPL System and the laundry machine from the power supply before making any connections. All the wiring connections to the LavoWash OPL System should be checked using a multimeter. Incorrect connections could seriously damage the unit and void the warranty. Refer to the wiring diagram in this manual for all powered connections.

Connecting Main Power

- Insert the cable through the conduit on the left of pump.
- Connect the power cord to the circuit board.
- Power connects to L, N, G located on the bottom right of the CB.
 - L = Line
 - N = Neutral
 - G = Ground
- The LavoWash OPL auto-detects the incoming electricity. The dispenser will accept voltage from 100VAC to 240VAC.

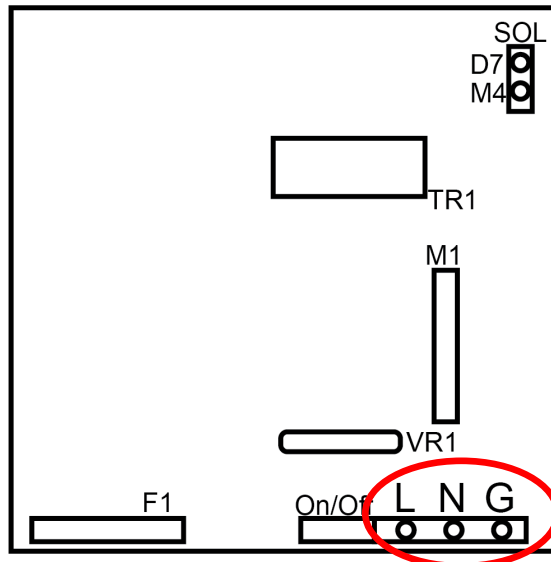

Connecting The Flush Solenoid

- Insert the cable through a conduit fitting on the bottom of the pump stand.
- Connect the leads from the solenoid to the circuit board.
- The leads connect to the top right of the circuit board.
- The solenoid power is 24VDC.

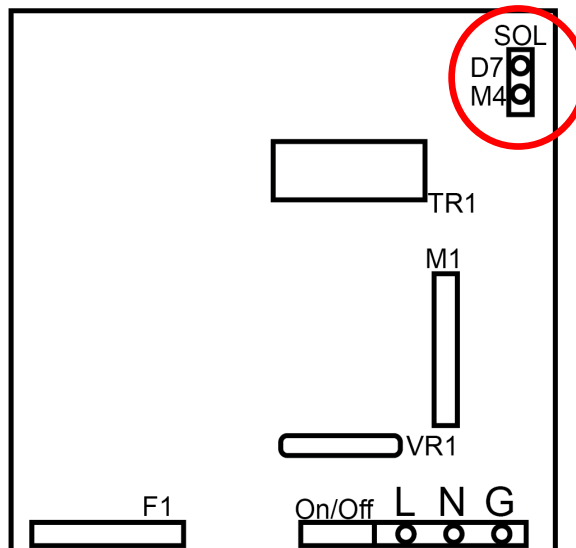

Electrical— Machine Interface

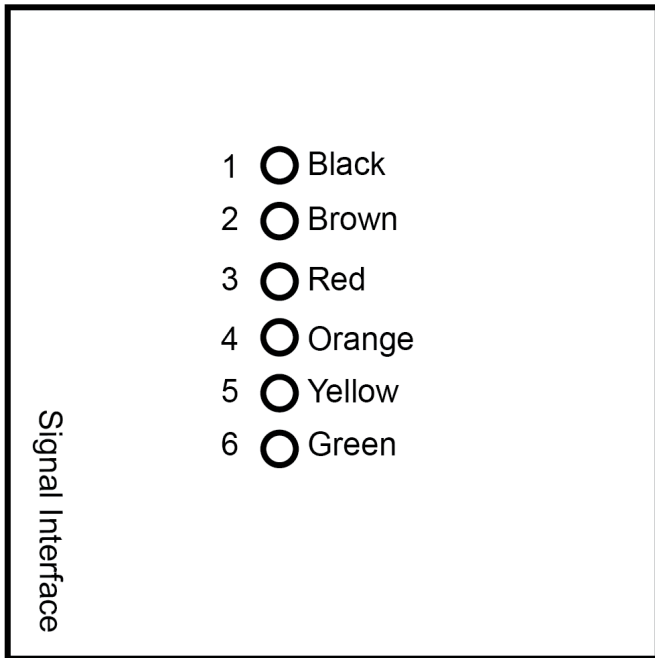

Pump	Wire Color	Common
1	Black	Black-COM
2	Brown	Brown-COM
3	Red	Red- COM
4	Orange	Orange-COM
5	Yellow	Yellow-COM
6	Green	Green-COM

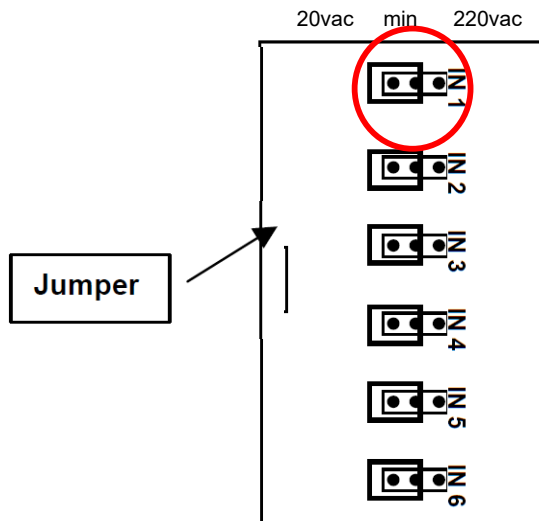

Adjusting The Signal Tolerance

- The tolerance of the Machine Interface can be adjusted to accept voltages from 24-240VAC or 70-240VAC.
- The standard is 24-240VAC
- If you need to adjust the tolerance to 70-240VAC, open the LEFT SIDE pump cabinet, locate the PCB and move the corresponding jumpers to the right two pins. See diagram to left.

ⓘ All signals received have a 5 second signal qualifying time.

👉 If you want use just one common, connect the “COM” wires to the common of the laundry machine.

👉 If you want use the drain counter, you need to connect the drain valve to Pump 1 (**Black-Black COM wire**) on the signal interface box.

👉 If the laundry machine has residual tension on the signal, please open the pump cabinet and move the jumper as show the picture above: adjusting signal tolerance.

Adjusting Flow Rates

Selection of the flow rate for the pumps

Use the jumper to select your desired flow rate as shown below. The default setting is 34 oz/min.

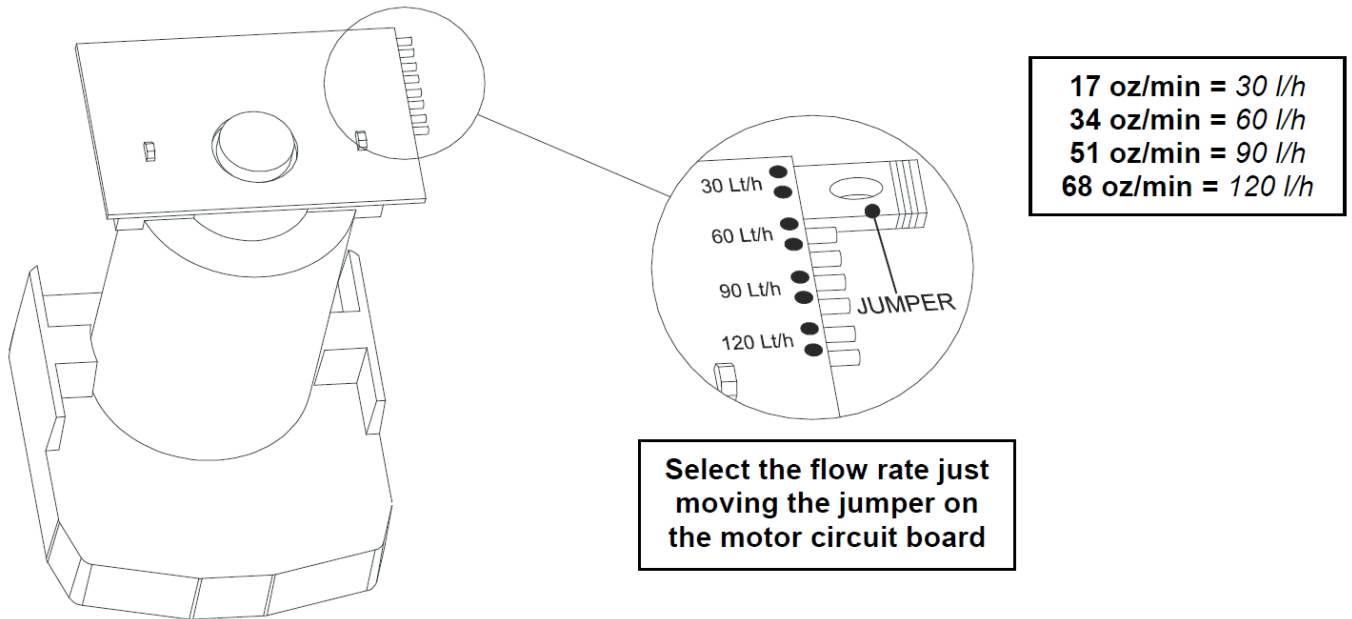

Picture 6

Pump Time Guide

 This chart can be used to program formulas prior to being at the installation site or for programming approximate relay-mode pump run-times.

 This chart is approximate and does not take into account different viscosities of products. Please use this as a starting point for calibration of products.

16.7 oz		33.3 oz		50 oz		66.7 oz	
Ounces	Run Time In Seconds	Ounces	Run Time In Seconds	Ounces	Run Time In Seconds	Ounces	Run Time In Seconds
1	4	1	2	1	1	1	1
2	7	2	4	2	2	2	2
3	11	3	5	3	4	3	3
4	14	4	7	4	5	4	4
5	18	5	9	5	6	5	4
6	22	6	11	6	7	6	5
7	25	7	13	7	8	7	6
8	29	8	14	8	10	8	7
9	32	9	16	9	11	9	8
10	36	10	18	10	12	10	9
11	40	11	20	11	13	11	10
12	43	12	22	12	14	12	11
13	47	13	23	13	16	13	12
14	50	14	25	14	17	14	13
15	54	15	27	15	18	15	13
16	57	16	29	16	19	16	14
17	61	17	31	17	20	17	15
18	65	18	32	18	22	18	16
19	68	19	34	19	23	19	17
20	72	20	36	20	24	20	18
21	75	21	38	21	25	21	19
22	79	22	40	22	26	22	20
23	83	23	41	23	28	23	21
24	86	24	43	24	29	24	22
25	90	25	45	25	30	25	22
26	93	26	47	26	31	26	23
27	97	27	49	27	32	27	24
28	101	28	50	28	34	28	25
29	104	29	52	29	35	29	26
30	108	30	54	30	36	30	27

Programming

Accessing the programming:

To enter the system:

- 1) Use “+” or “-“ to enter your password (default is 000) and after press **ENTER**;
- 2) The system will display **ACC** to show you have gained access.
- 3) The **pump time led** will begin blinking;
- 4) The number 1 will appear in the PUMP SELECT and FORMULA SELECT displays;

Clearing the memory

- Enter access code (see above);
- Hold simultaneously - **MODE** and **FORMULA SELECT** for 3 seconds;
- All the led will be off and the 3-digit display appears:
 - CLr displays for 10 seconds and then the system returns to normal operation.

PUMP/FORMULA - Programming Commands

After entering the access code, enter these PUMP/FORMULA commands to program functions:

Changing Access Code	Pump 1 + Formula A	Page: 23
Set Signal Lockout	Pump 2 + Formula A	Page: 23
Set Delay Units	Pump 3 + Formula A	Page: 23
Enable Drain Mode	Pump 5 + Formula A	Page: 24
Inverting Drain Mode	Pump 6 + Formula A	Page: 24
Level Enable/Disable	Pump 7 + Formula A	Page: 24
Set Reset Timer	Pump 8 + Formula A	Page: 25
Formula- enable/disable	Pump F + Toggle To Delay Mode LED	Page: 25
Flush Manifold	Pump F + Selected Formula Number	Page: 25

Priming with nothing programmed	Priming with formula programmed
<ul style="list-style-type: none">• Enter the access code;• The Pump Time LED will flash. If not, press the mode key so that the pump time LED is flashing.• Use the Pump Select key to choose the desired pump.• Press the CAL key to start and stop the pump.	<ul style="list-style-type: none">• Enter the access code;• The Pump Time LED will flash. If not, press the Mode key so the pump time LED is flashes.• Ensure Formula is set to "1" and use Pump Select key to choose the desired pump.• Press the Prime key to start priming the pump. The pump will run for the amount of time programmed.

Programming—Time Dosing

Step 1: Program with time or calibration

- Enter access code;
- The **Pump Time** LED should be flashing. If the delay time LED is flashing, press **MODE** to switch it back to **Pump Time**.
- Using the **PUMP SELECT** button choose the pump. **Then do one of the following:**

Programming based on time:

- If you know the time to achieve your desired dosage, simply use the “+” or “-” set the timing.
- You can also use the guide on page 10 to determine the time to enter.
- Press **ENTER** to save the times programmed.

Programming based on calibrating:

- Use a measuring cup to capture the pump output. Press “CAL” to start and stop the pump. Press **ENTER** to set the time after each pump is calibrated.

Priming with nothing programmed	Priming with formula programmed
<ul style="list-style-type: none"> • Enter the access code; • The Pump Time LED will flash. If not, press the mode key so that the pump time LED is flashing. • Use the Pump Select key to choose the desired pump. • Press the CAL key to start and stop the pump. 	<ul style="list-style-type: none"> • Enter the access code; • The Pump Time LED will flash. If not, press the mode key so that the pump time LED is flashing. • Use the Pump Select key to choose the desired pump. • Press the Prime key to start priming the pump. The pump will run for the amount of time programmed.

Programming—Time Dosing

Step 2: Program flush time Not using a flush? Disregard this step

- Enter access code;
- Dispense an ounce of chemical into the manifold.
- Choose **Pump F** and the **Formula Number** with the Pump and Formula select buttons.
- The pump time LED should be flashing. If not press MODE to choose pump time.
- Press CAL. The flush solenoid will open and the 3-digit display will start counting the flush time.
- Once the product is cleared from the line, press CAL again to stop the flush. The display will stop counting and the display will indicate the time needed to flush the line.
- Press ENTER and the display will flash and the flush time is set.
- Repeat for each formula.

OR

- You can manually program the flush time by selecting **Pump F** and the desired formula. Set the flush time with the “+” or “-“ buttons. Press **Enter** to save. Repeat for each formula.

Step 3: Setting the Load Count Pump

The load count pump of the LavoWash OPL performs a number of important functions.

- Counts total loads for each formula.
- Terminates programmed lockout times.
- Activates the system reset timer
- Resets “levels” on pumps 1 – 6.
NOTE: The pump used for load counts accepts only 1 wash level.

- Enter access code.
- Press and hold ENTER until the pump time and delay time LED's will be off. The current load count pump will be briefly displayed in the pump window.
- Use PUMP SELECT key for selecting the load count pump **number**. The display flashes during selection of the desired load count pump.
- When the pump time LED returns (in 3 seconds) the pump number was accepted

The FINAL pump is the same for all formulas.
DRAIN MODE: The final pump is 2 by default.

Programming—Time Dosing

Step 4: Programming Delay Time (Optional)

- Enter access code;
- Ensure that the delay time LED is flashing. If not, press **MODE** to select delay time.
- The 3-digit display shows 0 0 0 if delay units are seconds or - 0 0 if delay units are minutes;
- Use the **SELECT** buttons to choose desired pump and formula.
- Use to set the delay time;
- Press **ENTER** to confirm.
- Press **RESET**

Displaying The Load Count

- Press **ENTER**; The load count will be shown on the 3 digit window for the formula displayed;
- To see the statistic for each formula and pump, perform the following procedure:
- Formula: Press **FORMULA SELECT** to select the formula.
 - Press **PUMP SELECT** to select the pump.
 - If you set **Formula 0**, the 3-digit display reveals the total loads count for all formulas.
 - Clear load counts by pressing while the count is displayed until the 3-digit display shows 000.

Programming—Drain Mode

Step 1: Enable Drain Mode

- Enter the access code.
- Select Pump 5 and Formula “A”
- Use “+” or “-” to enable or disable drain mode.
 - Enable: Use “+” to change to 001
 - Disable: Use “-” to change to 000
- Press **ENTER** and then press **RESET**

Step 2: Assign Drain Numbers

- Enter access code.
- Press **MODE** until **pump time** and **delay time** led are simultaneously flashing.
- Select the formula & pump.
- Use to select the drain number (up to maximum of 15);
- Press **ENTER**;
- The display will be flashing briefly to indicate that the drain number is set.
- Repeat the same operation for all formulas and pumps used.
- Press **RESET**.

Step 3: Program Flush

- Enter access code.
- Select **pump F** and the formula;
- Use the “+” or “-” to choose the time the flush will remain ON.
- Do this for each formula.
- Press **ENTER** and then **RESET**.

Step 4: Inverting Drain Signal (Optional)

The drain solenoid valve can be set as NO (normally open) or NC (normally closed).

- Enter access code;
- Select **PUMP 6** and **FORMULA A**
- Use “+” or “-” to select 000 “NC” or 001 “NO”
- Press **ENTER**;
- The display will be flashing briefly to indicate that the new status has been accepted.
- Press **RESET**.

Programming—Drain Mode

Step 5: Programming Delay Time (Optional)

- Enter access code;
- Ensure that the delay time LED is flashing. If not, press **MODE** to select delay time.
- The 3-digit display shows 0 0 0 if delay units are seconds or - 0 0 if delay units are minutes;
- Use the **SELECT** buttons to choose desired pump and formula.
- Use to set the delay time;
- Press **ENTER** to confirm.
- Press **RESET**

Displaying The Load Count

- Press **ENTER**; The load count will be shown on the 3 digit window for the formula displayed;
- To see the statistic for each formula and pump, perform the following procedure:
- Formula: Press **FORMULA SELECT** to select the formula.
 - Press **PUMP SELECT** to select the pump.
 - If you set **Formula 0**, the 3-digit display reveals the total loads count for all formulas.
 - Clear load counts by pressing while the count is displayed until the 3-digit display shows 000.

Programming—Relay Mode

Step 1: Adjust the formula

- Enter the access code.
- Select **Pump “R”**
- Press **ENTER** and then **RESET**.

Step 2: Program Flush

- Enter access code.
- Select **pump F** and the formula;
- Use the “+” or “-” to choose the time the flush will remain ON.
- Do this for each formula.
- Press **ENTER** and then **RESET**.

Displaying The Load Count

- Press **ENTER**; The load count will be shown on the 3 digit window for the formula displayed;
To see the statistic for each formula and pump, perform the following procedure:
 - Formula: Press **FORMULA SELECT** to select the formula.
 - Press **PUMP SELECT** to select the pump.
 - If you set **Formula 0**, the 3-digit display reveals the total loads count for all formulas.
 - Clear load counts by pressing while the count is displayed until the 3-digit display shows 000.

Programming—AFS

Step 1: Enable AFS

IMPORTANT: AFS mode is only available in LavoWash OPL PLUS remotes.

- Enter the access code.
- Select Pump “A” and Formula “A”
- Use “+” or “-” to decide on which mode to operate. Use the table below as a reference.

Option	Signal Used	Description
Off	None	AFS Mode is off.
t 2	1	AFS Time Mode (time base is 2 seconds)
t 3	1	AFS Time Mode (time base is 3 seconds)
t 4	1	AFS Time Mode (time base is 4 seconds)
t 5	1	AFS Time Mode (time base is 5 seconds)
B 5	1-2-3-4-5	AFS Binary Mode (signal accepted at 5 seconds)
B10	1-2-3-4-5	AFS Binary Mode (signal accepted at 10 seconds)
B30	1-2-3-4-5	AFS Binary Mode (signal accepted at 30 seconds)

- Press **ENTER** and then press **RESET**

Programming continued on next page.

Important note:

- During AFS operation, the 3 digit window at the top will show AFS.
- The pump window will show nothing
- The formula window will show “-”
- When the formula is activated the formula window will indicate the formula that was selected based on your programming, and the system will wait for the next signal to begin dosing.

Programming—AFS Time Mode

Step 2: AFS Time Mode

- In time mode, you only need to connect **INPUT SIGNAL #1**.
- The formula is determined by the signal “ON” time divided by the Time Mode selected on the previous step.
- Use the chart below as a reference

Signal On (in seconds)	Time Mode Selection	Description
2	t 2	Formula 1 is selected. Signal is on for 2 seconds divided by time mode selection equals 1. (i.e. $2 / 2 = 1$)
4	t 2	Formula 2 is selected. Signal is on for 4 seconds divided by time mode selection equals 2. (i.e. $4 / 2 = 2$)
6	t 2	Formula 3 is selected. Signal is on for 6 seconds divided by time mode selection of 2. (i.e. $6 / 2 = 3$)
3	t 3	Formula 1 is selected. Signal is on for 6 seconds divided by time mode selection of 2. (i.e. $3 / 3 = 1$)
6	t 3	Formula 2 is selected. Signal is on for 6 seconds divided by time mode selection of 2. (i.e. $6 / 2 = 3$)
9	t 3	Formula 3 is selected. Signal is on for 6 seconds divided by time mode selection of 2. (i.e. $9 / 3 = 3$)

Programming continued on next page.

Programming—AFS Binary Mode

Step 2: AFS Binary Mode

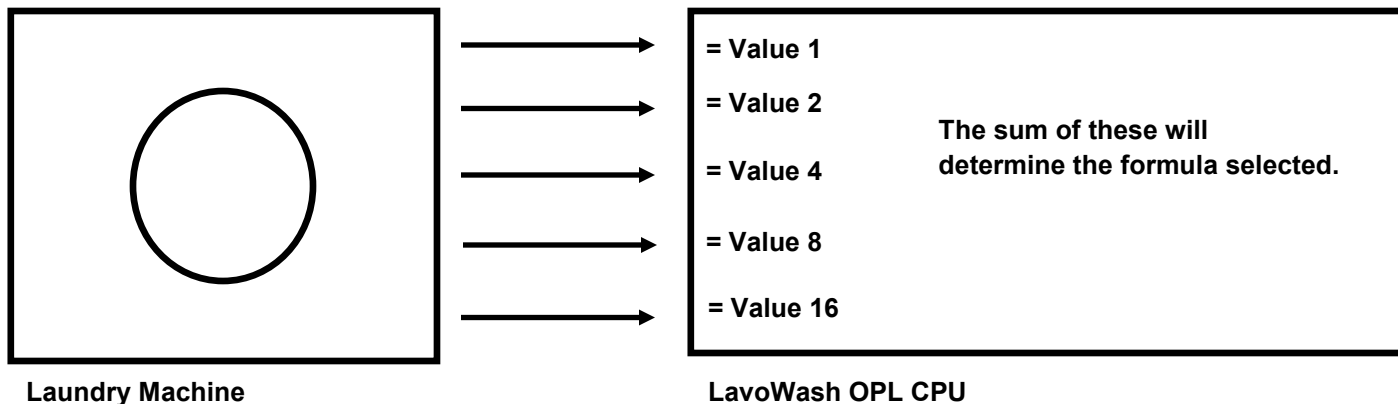

- The chart below shows the different combination of signals

Signal Input 1 (Value 1)	Signal Input 2 (Value 2)	Signal Input 3 (Value 4)	Signal Input 4 (Value 8)	Signal Input 5 (Value 16)	Sum of the value	Formula Selected
ON	-	-	-	-	1	1
-	ON	-	-	-	2	2
ON	ON	-	-	-	(1+2)=3	3
-	-	ON	-	-	4	4
ON	-	ON	-	-	(1+4)=5	5
-	ON	ON	-	-	(2+4)=6	6
ON	ON	ON	-	-	(1+2+4)=7	7
-	-	-	ON	-	8	8
ON	-	-	ON	-	(1+8)=9	9
-	ON	-	ON	-	(2+8)=10	10

Chart continued on the next page.

Programming—AFS Binary Mode

Step 2: AFS Binary Mode

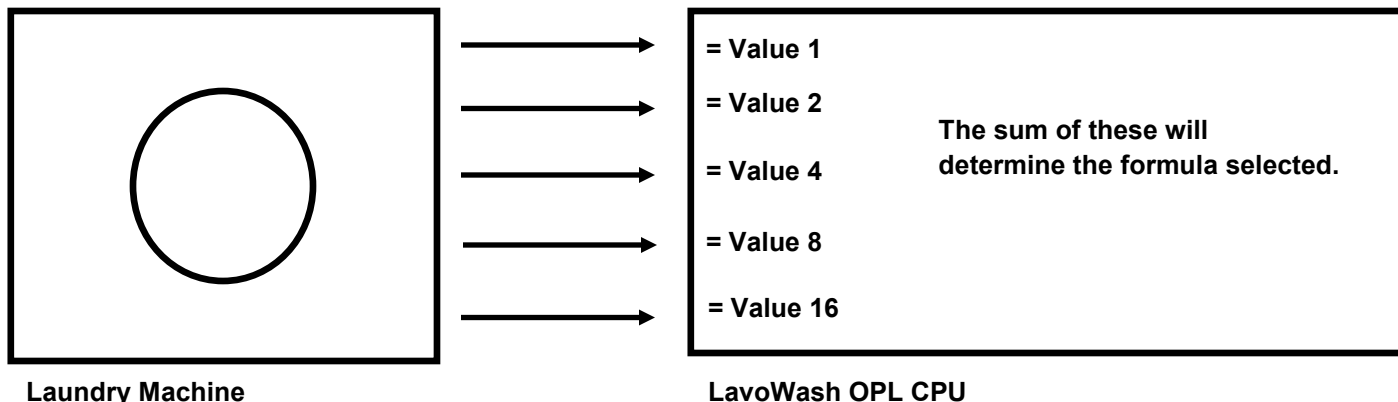

- The chart below shows the different combination of signals

Signal Input 1 (Value 1)	Signal Input 2 (Value 2)	Signal Input 3 (Value 4)	Signal Input 4 (Value 8)	Signal Input 5 (Value 16)	Sum of the value	Formula Selected
ON	ON	-	ON	-	$(1+2+8)=11$	11
-	-	ON	ON	-	$(4+8)=12$	12
ON	-	ON	ON	-	$(1+4+8)=13$	13
-	ON	ON	ON	-	$(2+4+8)=14$	14
ON	ON	ON	ON	-	$(1+2+4+8)=15$	15
-	-	-	-	ON	16	16
ON	-	-	-	ON	$(1+16)=17$	17
-	ON	-	-	ON	$(2+16)=18$	18
ON	ON	-	-	ON	$(1+2+16)=19$	19
-	-	ON	-	ON	$(4+20)=20$	20

NOTE: The formula will be activated after the filter time has been achieved.

- AFS binary selection of “b 10”
- Formula 6 will be activated when signals 2 and 3 are ON for 10 seconds.
- As soon as all signals are OFF, the remote control will show you the formula select (6), and the LavoWash OPL will dispense based on the times programmed in formula select.

Programming Commands

Change Access Code

- Enter access code; default is 000.
- Select **PUMP “1” and FORMULA “A”**;
- Select a new code with and then press **ENTER**;
- The 3-digit display will blink for 3 seconds to confirm the change.

Setting Lock Out Time

The lockout feature provides the option of preventing unwanted injections when supply signals are received more than once in a wash formula. (Not recommended in drain mode). The lockout available can be set for 0 – 75 minutes starting when a pump stops. Once the formula reaches the load count, the lock out will reset.

Example: If you set a 1 minute lock out time, after the end of dosing of pump 1, the LavoWash OPL will ignore the activation of the same signal for 1 minute.

- Enter access code;
- Select **PUMP “2” and FORMULA “A”**;
- Use to set the time.
- Press **ENTER**;
- The display will be flashing briefly to indicate that the new status has been accepted.
- Press **RESET**.

If a lock out is used in drain mode we suggest a lockout time longer than the sum of the dosing and the delay time of the pump.

Setting Delay Time Units

Pump delay times can be set in one second increments for 0 - 255 seconds, or one minute increments for 0 – 99 minutes. Determine the longest delay time required for the system, and select the appropriate delay time units.

- Enter access code;
- Select **PUMP 3 and FORMULA “A”**;
- Press to select 001(seconds) or 060(minutes) on the display:
- Press **ENTER** to confirm.
- Press **RESET**.

Programming Commands

Enabling Drain Mode

- Enter the access code.
- Select **Pump 5** and **Formula "A"**
- Use "+" or "-" to enable or disable drain mode.
 - Enable: Use "+" to change to 001
 - Disable: Use "-" to change to 000
- Press **ENTER** and then press **RESET**

Inverting Drain Signal

The drain solenoid valve can be set as NO (normally open) or NC (normally closed).

- Enter access code;
- Select **PUMP 6** and **FORMULA A**
- Use "+" or "-" to select 000 "NC" or 001 "NO"
- Press **ENTER**;
- The display will be flashing briefly to indicate that the new status has been accepted.
- Press **RESET**.

Level Enable/Disable

In normal operation, choose this option to disable the second level injection. The pumps will accept signals and run as normal with any future signals from the washer. (If the pump is not in a lockout time) In situations where the load count signal is skipped, either from operator error or machine malfunction, disabling levels can prevent a missed injection. This feature should be used in normal operation mode only.

Example: If you set a 1 minute lock out time, after the end of dosing of pump 1, the LavoWash OPL will ignore the activation of the same signal for 1 minute.

- Enter access code;
- Select **PUMP 7 and FORMULA A**
- Use to select 000 "Level enable" or 001 "Level disable"
- Press **ENTER**;
- The display will be flash briefly indicating the enable/disable status is set.
- Press **RESET**.

If a lock out is used in drain mode we suggest a lockout time longer than the sum of the dosing and the delay time of the pump.

Programming Commands

Setting Reset Timer

Use this feature when extra or “stray” signals are present during the final rinse or extract. This will allow for delaying the reset for up to 75 minutes from the time the load count pump starts. In the normal mode the reset time starts when the end pump goes on. In the drain mode the reset time starts when the end pump stops. When the reset timer activates, it resets the lock-out, the levels and the drain counter.

- Enter access code;
- Select **PUMP “8” and FORMULA “A”**;
- Use to select the time.
- Press **ENTER**;
- The display will briefly flash indicating that the new reset status is set.
- Press **RESET**.

Formula Enable/Disable

Use this feature when extra or “stray” signals are present during the final rinse or extract. This will allow for delaying the reset for up to 75 minutes from the time the load count pump starts. In the normal mode the reset time starts when the end pump goes on. In the drain mode the reset time starts when the end pump stops. When the reset timer activates, it resets the lock-out, the levels and the drain counter.

- Enter access code;
- Select **PUMP “F”**; The **delay time** led should be flashing. If not, press MODE to select delay time.
- Select the formula to be disabled or enabled.
- Use to select 000 “**Enable formula**” or 001 “**Disable formula**”
- Press **ENTER**;
- The display will briefly flash indicating that enable or disable has been set.
- Press **RESET**.

Program Flush

- Enter access code.
- Select **pump F** and the formula;
- Use the “+” or “-” to choose the time the flush will remain ON.
- Do this for each formula.
- Press **ENTER** and then **RESET**.

Troubleshooting

CAUTION: Before servicing, always disconnect the power supply and close the water delivery valve.

Problem	Solution(s)
<p style="text-align: center;">Pump not dosing</p>	<p>*Use extreme caution when working with electricity. Disconnect all power before starting any checks on the dispenser.</p> <ul style="list-style-type: none"> • Check the machine interface, does the indicator light turn on when a signal is received? <ul style="list-style-type: none"> • If so, check your programming, check the wiring from the motor to the CB. • If not, check the wiring to the washer. Also check to make sure a signal is being received from the washer.
<p style="text-align: center;">Loss of prime</p>	<ul style="list-style-type: none"> • Check the connection from the suction tube on the barb. • Check the squeeze tube. • Check the roller block and check to see if it is pressing on the squeeze tube.
<p style="text-align: center;">Pump going to number A and not dosing</p>	<ul style="list-style-type: none"> • Check your load count pump to ensure it is set to the final pump in the cycle.
<p style="text-align: center;">Pump dosing too much chemical</p>	<p>Adjust your formula to reduce the amount of time programmed.</p>
<p style="text-align: center;">Pump not dosing enough chemical</p>	<p>Adjust your formula to increase the amount of time programmed.</p>

Scheduled maintenance:

- Periodically check and replace squeeze tubes.
- Periodically check and replace suction and discharge tubes.
- Check the foot valve for debris, and clean or replace if necessary.

Terms & Conditions

Company warrants its Goods to be free from material defects in material and workmanship for a period of one year except: i. when Goods have been modified following delivery and/or subject to improper handling, storage, installation, operation, or maintenance unless those modifications have been authorized in writing by Seller. ii. when an item is purchased by Company as a component part of the Goods, except to the extent to which such item or items are covered by the warranty, if any, of the original manufacturer. iii. when an item which is a component part of the product has been furnished by Buyer. iv. no warranty of a component part shall extend beyond the warranty period of the device in which such component part is incorporated. b. There is no implied warranty of merchantability or of fitness for particular purpose and there are no warranties of any nature except as set forth in paragraph 3 herein. Any claim by Buyer made pursuant to Company's warranty must be made in writing. Company shall have the right to inspect the Goods claimed to be defective and shall have the right to determine the cause of such alleged defect. All Goods replaced or repaired by Company under its warranty shall be replaced or repaired F.O.B. Company's facility. Buyer must notify Company, in writing, within fifteen (15) days from receipt of Goods of any obvious defect in the product, or shortages, or Company shall have no obligation to correct such defect. Company shall have the option of re-inspection at Buyer's plant or its own before allowing or disallowing Buyer's claim. Defects that do not impair service shall not be a cause for rejection or recovery under any warranty. Buyer assumes full responsibility for the use and application of the product. Buyer accepts Company's design and material selection and specifications in placing this order unless other specifications are agreed to in writing by both parties prior to the manufacture of Goods by Company. Statements and data relating to Products on Seller's literature and website are not intended to define the performance of the product in actual usage or in combination with other equipment or processes. These statements should not be used by Customer solely as an indication of performance or suitability for specific applications or uses.

THE ABOVE WARRANTIES ARE THE SOLE AND EXCLUSIVE WARRANTIES MADE BY SELLER WITH RESPECT TO ALL PRODUCTS AND SERVICES.

Components and spare parts such as O-rings, squeeze tubes, roller blocks and other plastic components are considered to be wear parts and are not warranted. Seller shall have no warranty or liability for product that was damaged during shipment, product that is not being used in its recommended use, product that is not operated in accordance with the operating manual and procedures, product that was not properly installed, product used in a manner that is inconsistent with its designed purpose, product that is subject to a power surge or similar event, products that fail due to usage of a non Lavo Solutions replacement or spare part or product that was not maintained in accordance with recommended maintenance programs.

For full terms and conditions, please visit:
<http://lavosolutions.com/LAVO-T&C-02-2018.pdf>

Lavo Solutions, LLC
23192 Verdugo, Suite #D
Laguna Hills, CA 92653

O: 949-377-1250
W: www.lavosolutions.com