

 Connected

OPL- MultiLink Pro

LAVO Simple.
Clean.
Connected.

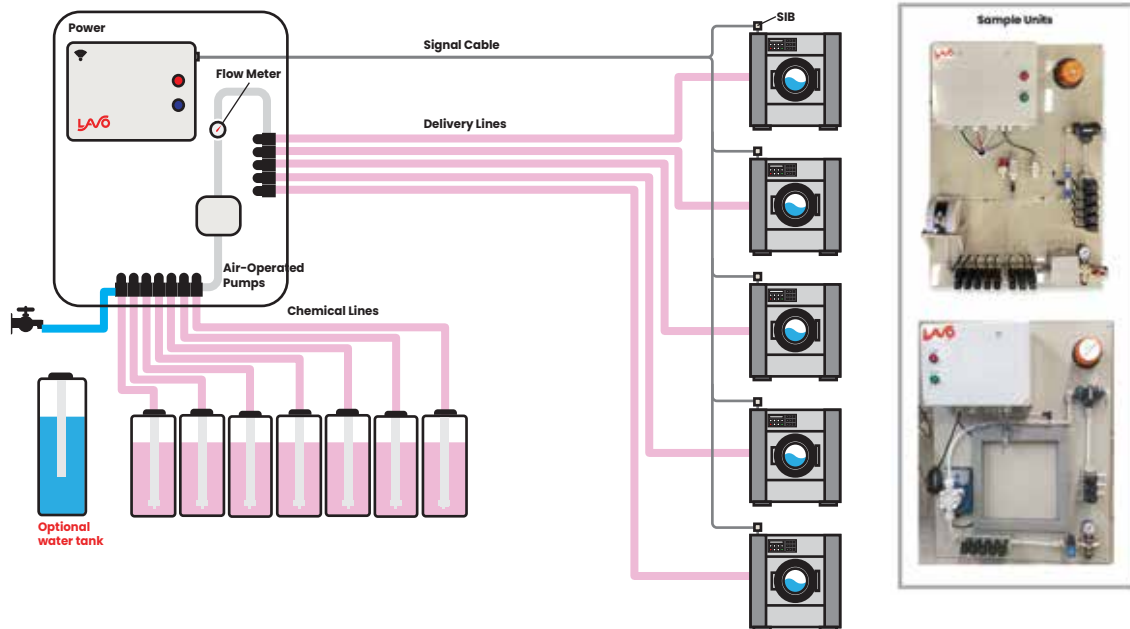

Key Features

- Controlled dosing and proof of delivery via flow meter technology
- Connects up to 5 washers and 8 chemicals on one panel
- 24/7 remote monitoring and access
- Remote calibration, programming and troubleshooting
- Cellular connectivity for uninterrupted service and safest data transmission
- Data encryption is standard
- Air assisted flush available
- Installation hardware kits available

Specifications

- Pump Output: 1.3 gal/min (5 L/min)
- Voltage 120/240 VAC 50/60Hz
- Tubing recommendation: 3/8 ID (inlet / outlet)
- Isolated inputs 24VDC up to 230 VAC
- IP65 rated electronics enclosure
- Pneumatic or electromagnetic pumps
- Cellular based 3G / LTE
- Recommended max washer capacity: 450lbs
- Water connection: 1/2" hose barb
- Air connection: 1/4"OD push to connect

Spare Parts

- Pneumatic or Electromagnetic pump
- 24 VDC air distributor valve
- 24 VDC electric distribution valve